

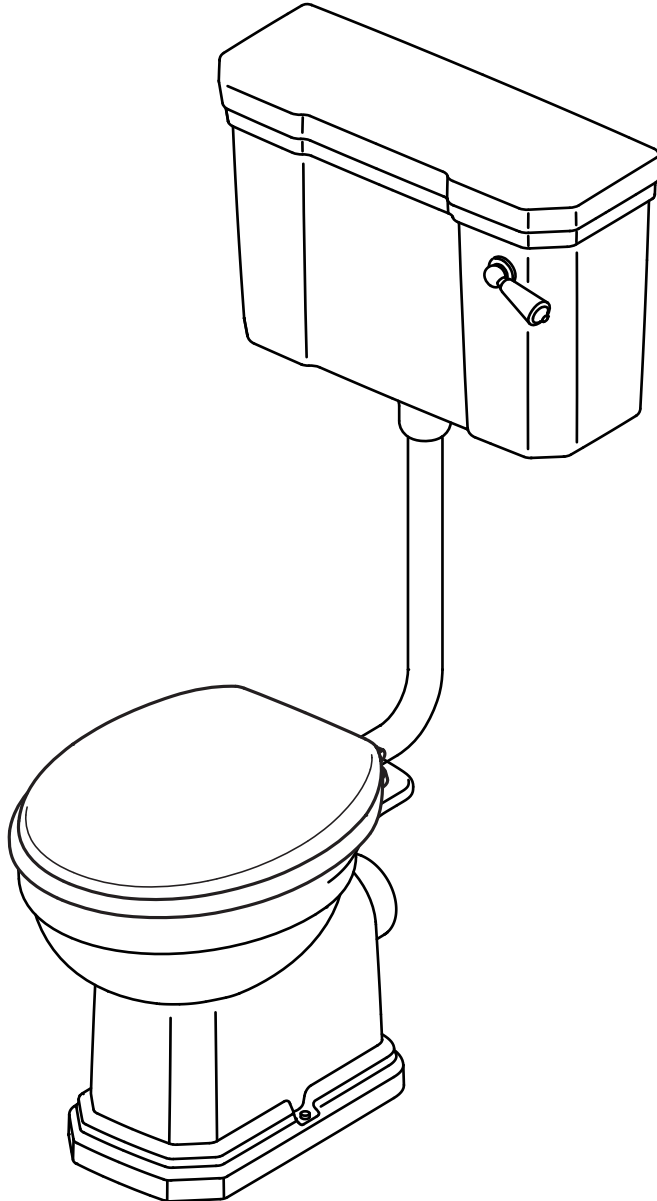



WAVERLEY



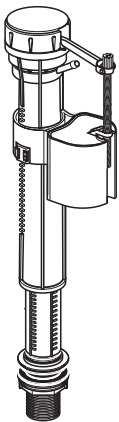

# Low Level WC Suite



Assembly and  
Installation Instructions

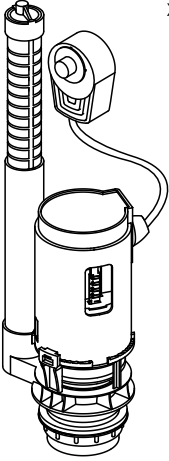



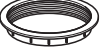

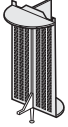
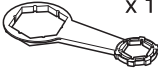

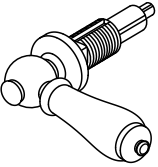
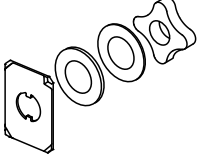

# Parts Supplied

<b>A</b>	<b>B</b>
 x 1	 x 1 Tapered Rubber Washer
	<b>B1</b>
	 x 1 Flat Rubber Washer
	<b>B2</b>
	 x 1 Flat Plastic Washer
	<b>B3</b>
Inlet Valve	 x 1 Inlet Valve Backnut

<b>C</b>	<b>D</b>
 x 1	 x 1 Tapered Rubber Washer
	<b>D1</b>
	 x 1 Flat Rubber Washer
	<b>D2</b>
	 x 1 Flat Plastic Washer
	<b>D3</b>
Flush Valve	 x 1 Flush Valve Backnut

<b>E</b>	<b>F</b>
 x 1	 x 1 Plastic Spanner
	<b>G</b>
	 x 1 Flow Restrictor
Filter	

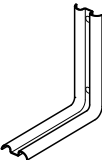
<b>H</b>	<b>I</b>
 x 1	 x 1
Cistern lever	Cistern Lever Fixings

<b>J</b>	<b>K</b>	<b>O</b>
 x 1	 x 1 Olive	 x 1 Shroud
	<b>L</b>	
	 x 1 Coupling nut	
	<b>M</b>	<b>P</b>
	 x 1 "O" ring	 x 2 Wall Brackets
Chrome Flush Pipe	<b>N</b>	
	 x 1 Pan inlet connector	

## **Tools Reuired (not supplied)**

- Adjustable Spanner
- Screwdriver
- Spirit Level
- Tape Measure
- Pencil or Marker Pen
- Power Drill and suitable bit(s)

## **Parts Required (not supplied)**

- Brass Screws and Fixing Plugs to secure the cistern to the wall
- Brass Screws and Fixing Plugs to secure the pan to the floor

## **Before You Start**

- Check the pack and make sure you have all the parts listed. If not, contact the vendor who will be able to help you.
- When you are ready to start, make sure that you have the right tools to hand, plenty of space and a clean, dry area for assembly.
- Ensure the water feed and waste connection points are positioned appropriately for the installation.
- **Caution:** Care should always be taken when drilling into walls and floors to avoid any sunken wires or pipes.
- Operating water pressure for inlet valve 0.2 Bar - 8.0 Bar.
- **Please Note:** Although these instructions are comprehensive, it is always recommended that a technically competent installer should undertake installation.
- **Servicing valve:** The Water Regulations have a requirement to fit a servicing valve adjacent to the cistern. (Not supplied).

## **WARNING**

**Do not use or drop any chlorine or chemical related components into the cistern or WC. Use of such products will:**

- (a) Result in damage to tank components, and may cause flood and property damage.
- (b) Void warranty

**Do not overtighten nuts or tank / bowl may crack.**

# Cistern Assembly

1. Setup the inlet valve to the correct height (see page 6 for settings).

2. Remove the backnut and washers (B1, B2 & B3) from the inlet valve (A). Insert the inlet valve through the hole in the base of the cistern, ensuring the washer (B) is in place to seal and centralise the valve in the hole. Secure the inlet valve in position with flat washers & backnut, making sure the inlet valve is not in contact with the cistern wall.

3. Check the flush valve is set to correct settings (see page 5 for settings).

4. Remove the backnut and washers (D1, D2 & D3) from the flush valve (C). Insert the flush valve through the hole in the base of the cistern, ensuring that the washer (D) is in place. Fit the flat washers then secure using backnut, making sure that the flush valve is not in contact with the inlet valve or cistern wall.

5. Check all joints to ensure they are watertight.

6. Slide olive around top of flush pipe (flat side facing down) and push flush pipe up the tail of the outlet valve and then tighten the coupling nut onto tail to obtain a seal.

7. Slide shroud onto pipe followed by the retaining 'O' ring.

8. Fit pan inlet connector to flushpipe ready to connect to pan.

Do not overtighten.

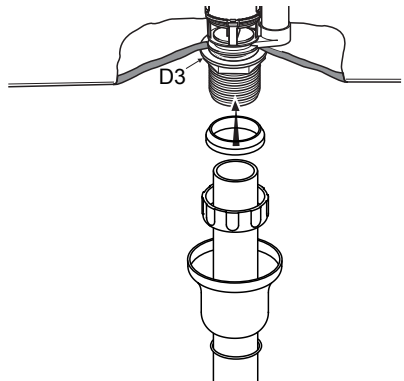
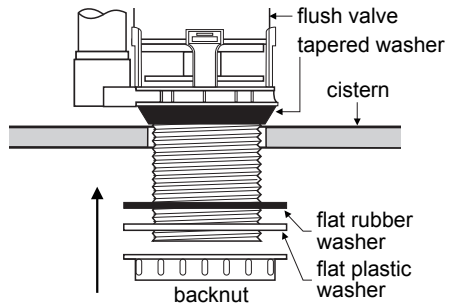
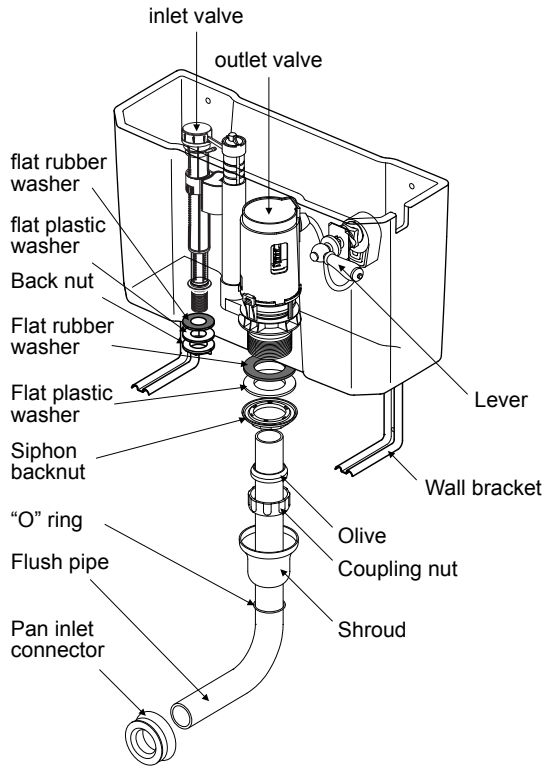

## Flush Valve Installation

1. Turn flush valve body anticlockwise and lift, parting it from flush valve seat.

2. Adjust valve settings to chart below by moving centre float, full and half adjusters up or down.

3. Refit valve

4. Adjust overflow pipe height by pulling cap, see chart for setting dimension. When set, twist to lock in position N.B. Minimum setting does not require locking.

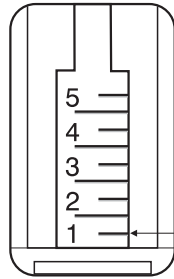

example of centre float setting

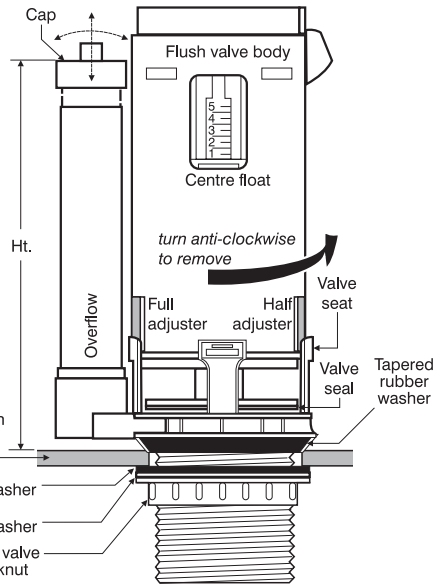

## Setting the Valve to Correct Flushing Volumes

Set valve to table **BEFORE** fitting into cistern

Flush Volumes (litres)	Full adjuster	Half adjuster	Centre float	Overflow Height (mm)	W.L. Height (mm)
6 / 4	2,5	full	1	185	

## Connecting Water Supply and Waste

If water pressure exceeds 3.5 Bar then fit the flow restrictor prior to fitting the filter in the inlet valve stem. Ensure both filter and flow restrictor are fitted the right way up as shown opposite.

Connect water supply and waste connections.

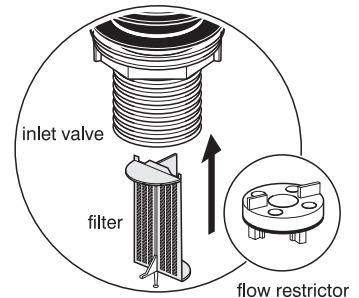

## To Set The Water Level

Turn on the water supply and allow the cistern to fill. Adjust the float by twisting the float stem on the inlet valve so that the valve stops the flow of water when the water reaches the required marked water line.

(Water line indicates full flush volume).

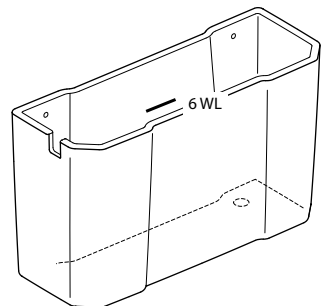

## Inlet Valve Installation

Unscrew the nut and remove both the plastic and rubber washer(optional). Insert the fill valve into the installation hole at the bottom of the tank and then install the rubber and plastic washer (optional) and tighten hex nut. **Installation torque recommendation:**

1. Recommended torque for locknut with rubber washer and plastic washer or with plastic washer only is 4~6 N.M. (Newton Meters)
2. Recommended torque for locknut without rubber washer and plastic washer is 7~10 N.M. (Newton Meters)

**Remark:** Please observe if there is any leakage after installation. After tightening the nut, ceramic installation hole may distort and can result in leaking.

For the valve to be installed correctly, the Critical Level mark on fill valve, (C.L. mark on valve body) should be at least 25mm above top of overflow pipe. If pressure exceeds 3.5 Bar then fit the flow restrictor (G) prior to fitting the filter in the valve stem. Ensure both filter (E) and flow restrictor are fitted the right way up as shown opposite. (Flow restrictor not required for pressures below 3.5 Bar.) Filter to be cleaned regularly.

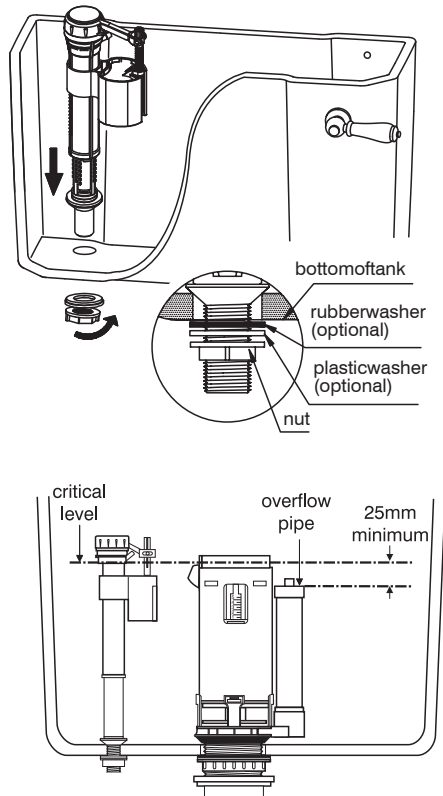

# Inlet Valve

## Major Height Adjustment

- A** Remove locking clip by pushing downwards
- B** Loosen valve body anticlockwise adjust to required height, and tighten clockwise
- C** Re-fit locking clip

## Minor Height Adjustment

- D** Realise locking device in direction shown.
- E** Adjust top of cup to approximately 7mm below the water line, and rotating float screw taking top surface of the float to within 2-4mm below top edge of cup.
- F** Engage the locking device in direction shown. Turn on water supply and check water level position. Use float screw for final adjustment.

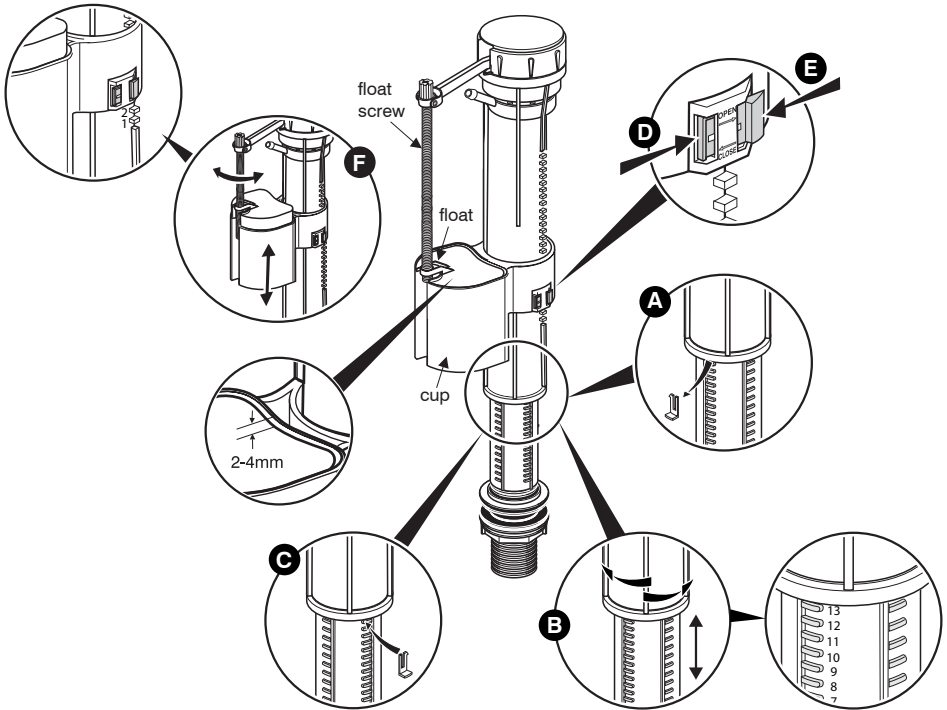

Connect the water supply to the inlet valve. Turn on the water supply and allow the cistern to fill. Adjust the float on the inlet valve so that the valve stops the flow of water when the water reaches the waterline marked in the cistern. Check for leaks.

## **WC Pan and Cistern Fixing**

Place the cistern in the required position. With cistern lid removed, mark the position of the screw holes in the rear of the cistern and cistern wall mounting brackets. Remove away from its location and drill and plug the positions. Fit the brackets to the wall. Place cistern on the brackets and secure to the wall.

Place the pan in the required position and mark the position of the screw holes in the base of the pan. Remove the pan away from its location and drill and plug the positions marked on the floor. Replace the pan in position, connecting waste outlet (not supplied) and secure to the floor using suitable fixings (not supplied). Ensure the flushpipe is securely inserted in to the back of the pan.

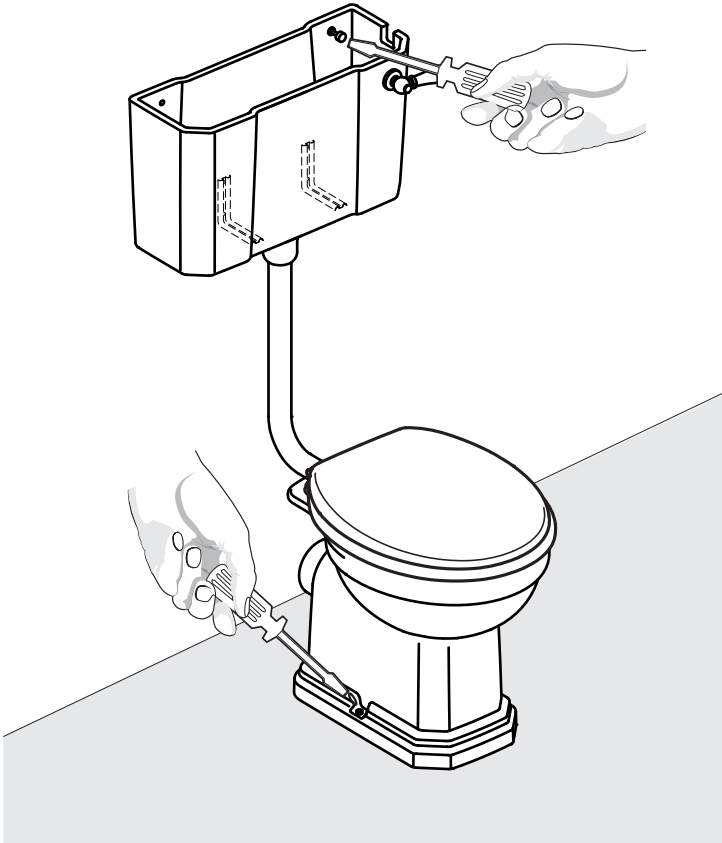
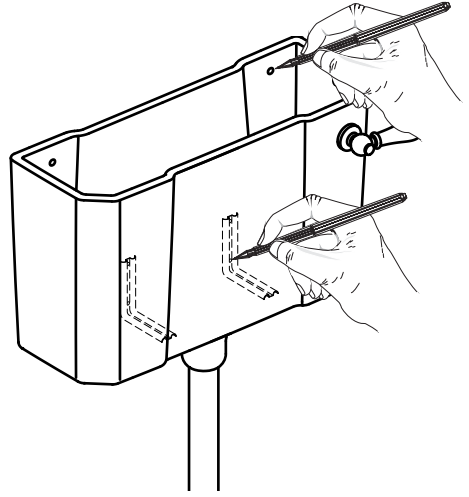



# Install Lever

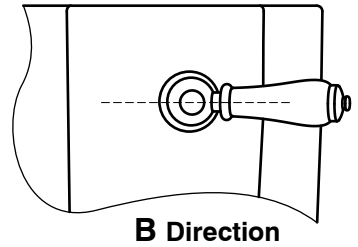
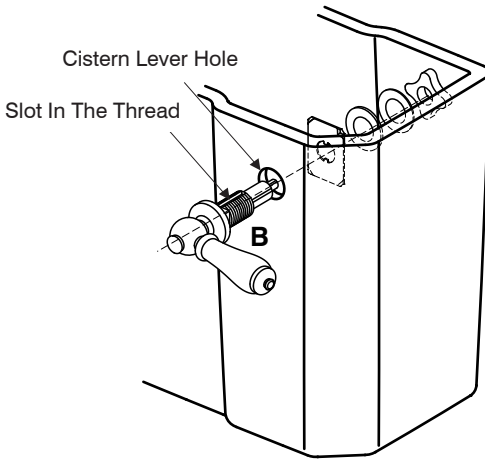
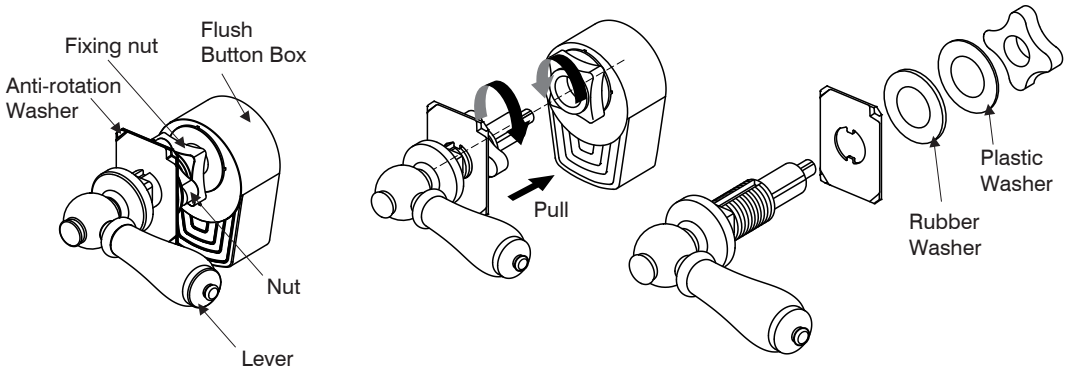

- With the lever facing outward and the slot on the thread facing upwards, fix the lever to cistern.

- The fixing nut should be tightened as much as possible to avoid the cistern lever working loose during operation.

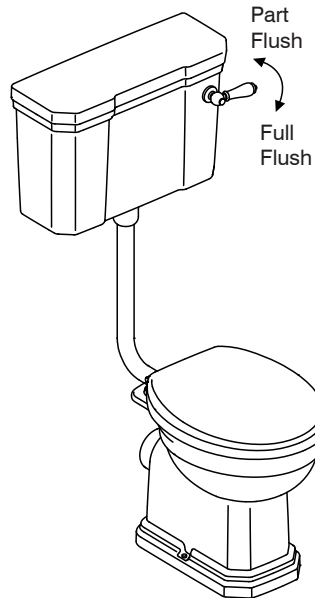
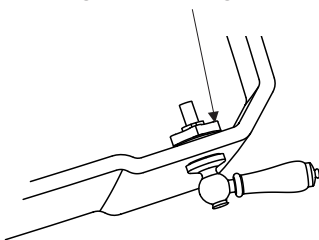

## **Product Care**

---

All our products are designed, manufactured and supplied to give many years of reliable service, provided they are properly maintained and cared for. These are our recommendations to make sure that your bathroom stays looking good:

### **Vitreous China – Ceramic toilets, cistern tanks**

#### **Do's**

Use warm soapy water, cream or liquid cleaner.

Occasional use of mild bathroom lime scale removers is acceptable.

Use in accordance with manufacturers instructions, rinsing well with plenty of water.

Inlet valve filter to be cleaned regularly.

#### **Don't**

Do not put bleach products in the cistern – this can damage the internal fittings.

It is acceptable to use in the toilet bowl itself.

Never put strong cleaner or bleach in overnight.

Never mix different cleaners in the WC – they can react to give off poisonous gas.

### **Plastic WC Seats**

#### **Do's**

Clean immediately after use to stop a build up of dirt and scale.

Use warm soapy water, Cif cream cleaner or Domestos Multi Active surface cleaner.

Polish out minor scratches and abrasions with a mild polishing compound.

#### **Don't**

Never leave pools of soap, shampoo or cleaning detergent (please see above) – these can cause permanent stains.

Never let cigarettes/flames near - your seat can burn and melt.

Never use household chemicals – a range of products such as paint stripper, nail varnish remover, household bleach, perfume, aftershave or strong disinfectant.

We cannot recommend the use of any scouring products or cream cleaners other than Cif.

Never mix different cleaners on your seat – they can react to give off poisonous gas.

## **CUSTOMER CARE HELPLINE**

**0870 1258905**

**FAX LINE 01482 499611**

**email: [ukcustcare@IdealStandard.com](mailto:ukcustcare@IdealStandard.com)**