

TREVI BLEND

SINGLE LEVER SHOWER VALVES



TREVI
by Ideal-Standard

Installation Instructions
A3086 Trevi Blend Exposed
A4000 Trevi Blend Built-in

INSTALLER:
After installation please pass this
instruction booklet to user

This installation instruction covers both versions of the Trevi Blend. Built-in (A4000) and Exposed (A3086) for concealed and exposed pipework.

The Trevi Blend is a mechanical mixing valve operated by a single lever. Lifting the lever up operates the flow control and rotating it changes the blend temperature.

Rotating to the left increases the temperature and to the right reduces it.

The Trevi Blend incorporates a "Blend

Control" which is a mechanical stop, located under the lever handle, which should be pre-set by the installer to limit the maximum temperature. It does this by limiting the angle to which the lever can be moved towards the hot position. There are five possible settings for the blend control. It should be emphasised that the blend control is not a thermostat.

The exposed version is supplied with compression fittings allowing it Trevi Blend to be fitted directly to 15mm copper plumbing.

Connections to the built-in version are $\frac{1}{2}$ " BSP.

Water supplies

The Trevi Blend fitting can be fitted on both low pressure vented and high pressure unvented systems. When installing on conventional UK tank fed hot water storage systems (low pressure vented) it is important consider the following factors.

1. A minimum head of one metre is required between the bottom of the storage tank and the operating position of the showerhead.
2. Both hot and cold supplies should be fed from the storage tank.
3. For safety reasons the tapping on the storage tank for the hot feed to the cylinder should be higher than the tapping for the cold feed.
4. Supplies to the shower should be led under the floor if possible otherwise air locking could occur. If supplies must be led above the shower valve, the pipes must be vented at the highest point.

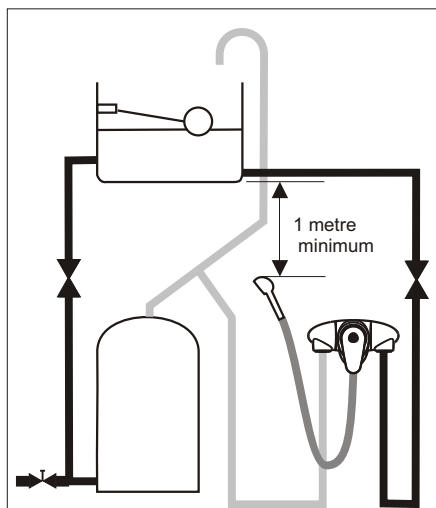

Figure 1. Conventional UK tank fed hot water storage system

The fittings covered by this installation and maintenance instruction should be installed in accordance with the water regulations published in 1999*, therefore, American Standard would strongly recommend that these fittings are installed by a professional installer

Unvented Systems

The Trevi Blend can be fitted to most types of unvented system. (Typical systems are illustrated below.)

Hot and cold supply pressures should be

balanced and in the range 1 bar to 5 bar (ideally 2 bar to 3 bar)

Combination boilers and instantaneous gas water heaters should be of a fully modulating design. Servicing valves should be fitted immediately upstream of the Trevi Blend.

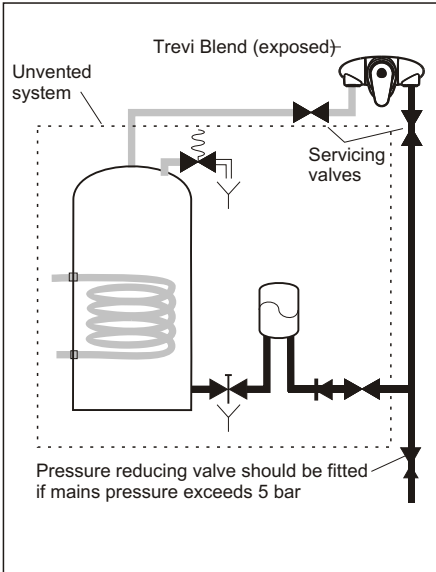

Figure 2 Unvented mains pressure storage system

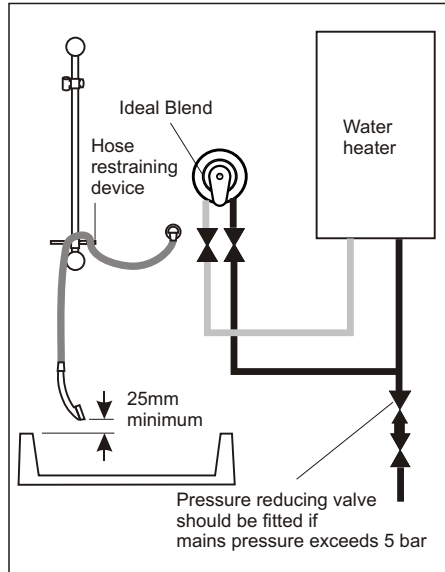

Figure 3 Instantaneous gas water heater or combination boiler system

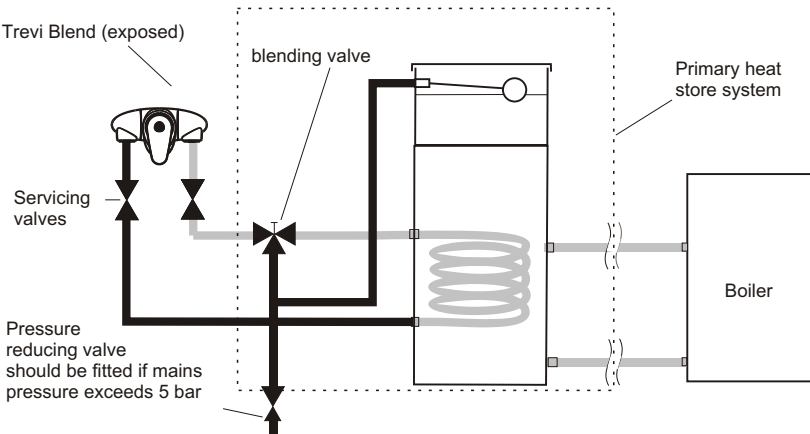

Figure 4 Mains pressurised thermal heat storage system

The water regulations published in 1999* take a new approach to backflow in that they look at different categories of risk. The installer must assess the risk from the various categories of fluid in adjacent appliances before determining the level of backflow protection required for a particular installation. The following diagrams outline the protection required in various installations.

Water in a shower tray, basin or bathtub is considered to be a fluid category 3 risk which is a fluid which represents a slight health hazard if it were to find its way back into the

supply pipe. For this reason it must not be possible for any flexible shower head to be able to enter any adjacent washbasin, bath or shower tray unless appropriate protection is employed. (Figure 5)

If it is desired to allow the handspray to be used inside say a bathtub or a basin it is essential that double check valves be fitted to the inlet on both hot and cold supplies to the Trevi Blend. Alternatively single check valves may be fitted on the inlets and an additional check valve at the valve outlet.

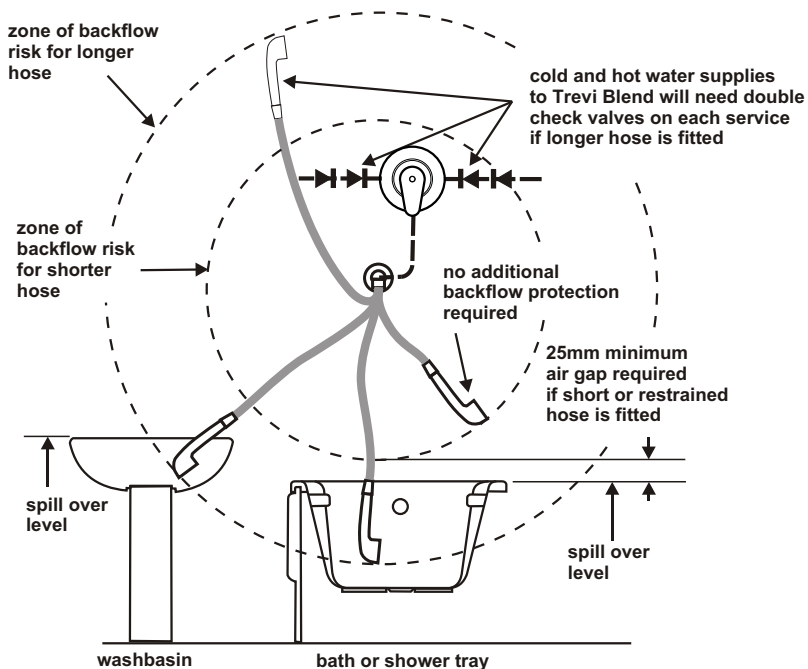

Fig 5 Backflow risk from a fluid Category 3

*A guide to the Water Supply (Water fittings) Regulations 1999 and the Water Byelaws 2000, Scotland is published by WRAS (Water Regulations Advisory Scheme) Fern Close, Pen-y-Fan Industrial Estate, Oakdale, Newport, Np11 3EH. ISBN 0-9539708-0-9

Water in a Sink, WC or Bidet is considered to be a fluid category 5 risk which is a fluid which represents a serious health hazard if it were to find its way back into the supply pipe. For this reason it must not be possible for any flexible shower head to be able to enter any adjacent Sink, WC or Bidet. If the flexible hose to be fitted could reach into any such vessel, the requirements to the system design are so onerous it is better not to fit a flexible. Rather,

a fixed overhead showerhead should be considered. (Figure 6)

It will also be seen that this risk could change should the hose be taken out of the restraining device or should a longer replacement hose be fitted at a later date. Installers and householders are advised to take account of these factors when fitting replacement hoses.

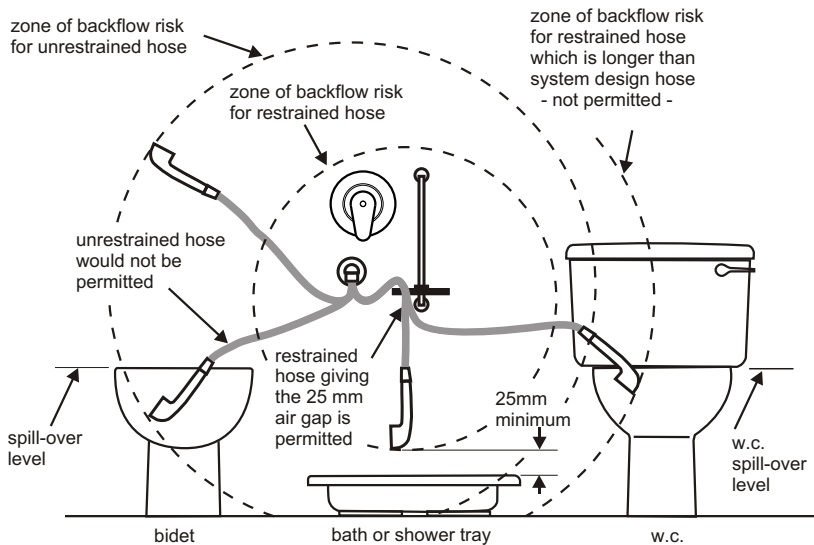

Fig 6 Backflow risk from a fluid Category 5

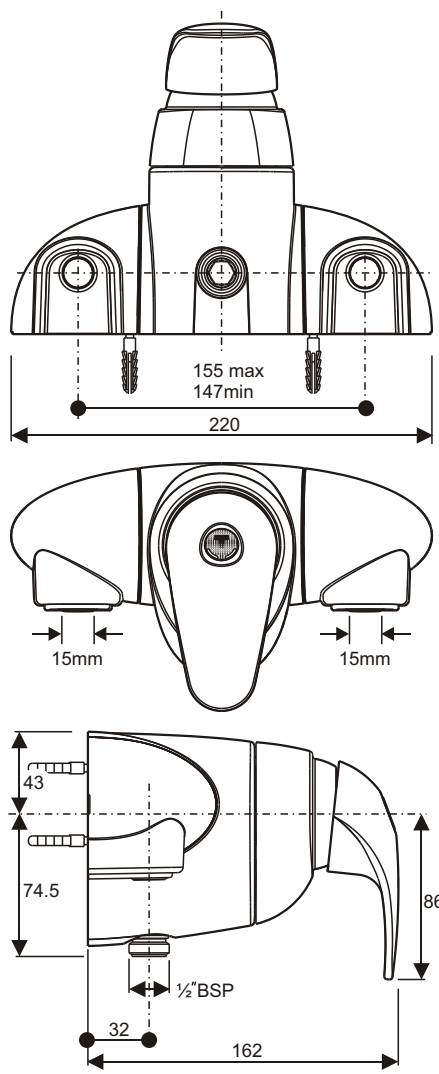

Figure 7
Trevi Blend Exposed A3086

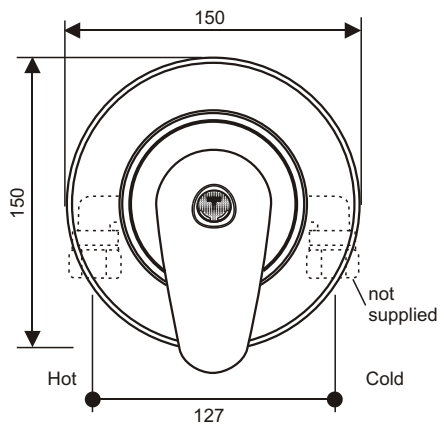
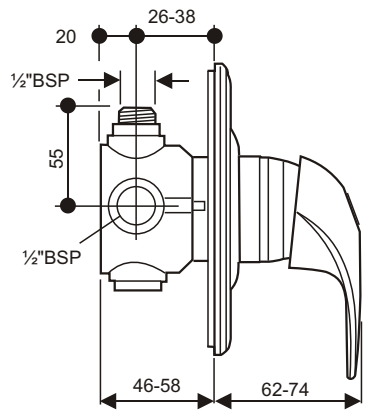

Figure 8
Trevi Blend Built-in A4000



Installation Built-in

1. Fit inlet connectors (16 not supplied) to the ½"BSP connections in the orientation required. Thread tape or plumbers compound will have to be used to seal them into the brass body casting.
2. Check the sealing o-rings (14) are present then fit the blanking plug (12) and outlet nipple (15) in the positions required. Ensure both are tight.

For solid walls

3. Cut a recess to allow the fitting to be recessed to a depth of between 46mm and 58mm from the finished wall surface. Secure valve body to back of the recess using fixing lugs (20).

For cavity walls

4. The normal method of installing in a cavity wall is to fit a wooden noggin between the wooden studs at a suitable depth to permit the back surface of the valve body to be screwed to its surface. The noggin should be set at a depth of 46 - 58 from the finished, tiled wall surface.
5. However, a metal mounting bracket may be the best method of mounting when installing built-in valves into walls of timber construction with large cavities and plasterboard facing. The bracket (41), which is an optional extra, will provide stability and ensure that the body is installed at the correct depth. See Figure 9. The bracket is available from Trevi stockists or directly from Trevi Showers - contact 0870 129 6086 quoting part number L6714NU
6. Complete the in-wall plumbing.
7. Turn on water supplies and test for leaks. (Blank off spray head connection to ensure outlet pipe work is tested under pressure).
8. Before attaching the shower head, open the Trevi Blend flow control and flush any debris from the system.
9. Fit the plaster guard (18) and check wall levels agree with those marked on the guard.
10. Complete the plastering and tiling. When

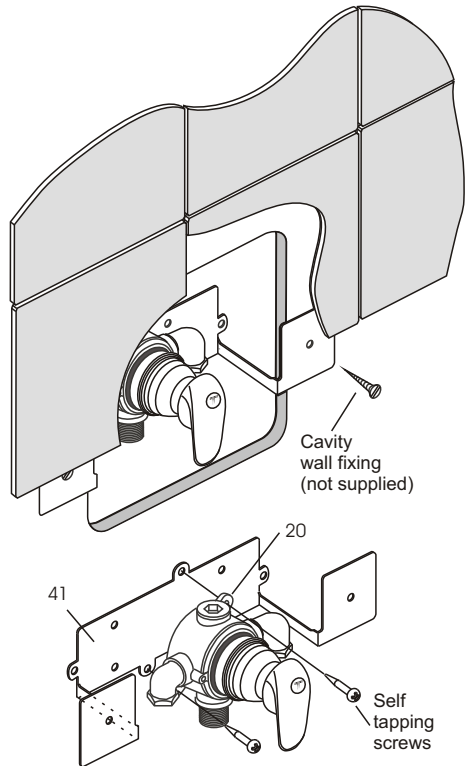

Figure 9 Mounting B/I valve on wall bracket

the bracket is used tile directly over the wall mounting flanges as the bracket material is thin enough to be accommodated in the adhesive layer.

Figure 9

11. Ensure the small drainage hole in shield (3) is located at the bottom.
13. Fit cover plate (5a) and trim (5b) as appropriate.
14. Fit operating handle (1) and secure using washer and nut. (A 10 mm A/F box spanner is supplied with the fitting for this purpose).

Installation Exposed

Connections to the exposed valve are 15mm compression. Decide which configuration of pipe work is to be used and adjust centres (adjustable between 147 mm and 155 mm) of the elbows (31) by screwing them in/out to the desired dimension. Connect the fitting

(loosely at this stage as the cover slips still have to be fitted) to the pipe work. Red and blue stickers on the back plate indicate that hot is on the left and cold on the right. Mark the position of holes for fixing screws (32). Remove fitting from pipe work and drill and plug the wall. If installing with surface pipe work, fit the elbow cover pipe slips (4) to the pipes. Reconnect the fitting to the supplies. Screw fitting to wall and fit elbow covers (7) ensuring that the lugs on the pipe slips engage behind the cover (7).

Setting the blend control

The blend control is a simple mechanical limit stop, located under the single lever handle, which restricts the angle to which the handle can be rotated towards the full hot position. To set it, the hot water system should be on and the hot water up to normal working temperature.

A thermometer will be required to measure the maximum blend temperature.

1. Remove the handle (1) by undoing the nut (2a) using the 10 mm A/F box spanner and removing the washer (2b). Pull off handle
2. Remove face plate (5a/b).
3. Pull off shield (3).
4. The blend control stop (white crescent shaped plastic moulding) can then be removed. (In it's factory set position "0" - shown dotted in Figure 10 - it does not limit the lever handle movement so the highest

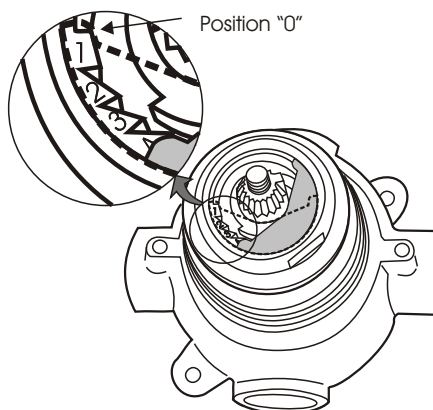

Figure 10. Setting the blend control

- possible temperature will be possible).
5. Insert the limit stop in position 4 (shown shaded in Figure 10)
6. Operate the shower and measure the temperature at the maximum setting.
7. If not high enough reposition the stop in position 3 and recheck the temperature.
8. Repeat the process until the temperature at the maximum setting is satisfactory.
9. Refit the shield (3) and handle (1) and check that the maximum blend temperature is still satisfactory.

Note: The maximum temperature to which the blend control limit stop is set will usually be a few degrees above normal showering temperature. e.g. approximately 43°C.

Maintenance

The Trevi Blend fitting should be cleaned regularly using a mild detergent, rinsed with warm water and dried with a clean soft cloth. In hard water areas the spray head will require to descaled from time to time using a proprietary lime scale remover always follow the manufacturers instructions on the label. The unique Multiport ceramic disc cartridge contains ultra-smooth ceramic discs. These

are so hard that they always remain sealed together, polishing each other in use. Sand, sediment and other water borne matter cannot get between them or damage them. Even the hardest water has no effect and this means that the Trevi Blend fitting should give many years of efficient trouble free service without the drip and liming up problems associated with traditional valves.

However, in the unlikely event of a failure or any other problem, it is a simple matter to exchange the cartridge. Before doing so, however, it is best to check that the showerhead has not become blocked with lime scale.

Cartridge Replacement

1. Remove lever handle (1). (A 10 mm A/F box spanner (40) is supplied with the fitting for this purpose.)
2. Remove cover plate (5.x) by removing screws (4).
3. Pull off shield (3.x)
4. Unscrew cartridge retaining nut (9.x) and place on a clean piece of paper to ensure

the grease on the o-ring does not pick up any grit.

5. Pull cartridge out ensuring that the cartridge spacer (12) is not dislodged. If it is, reposition it ensuring that the moulded location pin engages in the hole on the base plate inside the valve body.
6. Position the replacement cartridge ensuring that the moulded location pin engages in the hole on the cartridge spacer.
7. Refit retaining nut (9.x) and tighten to a torque of 4 N/m. (A plastic spanner is supplied with the replacement cartridge which will apply this torque when the central lever just touches the edge of the slot).

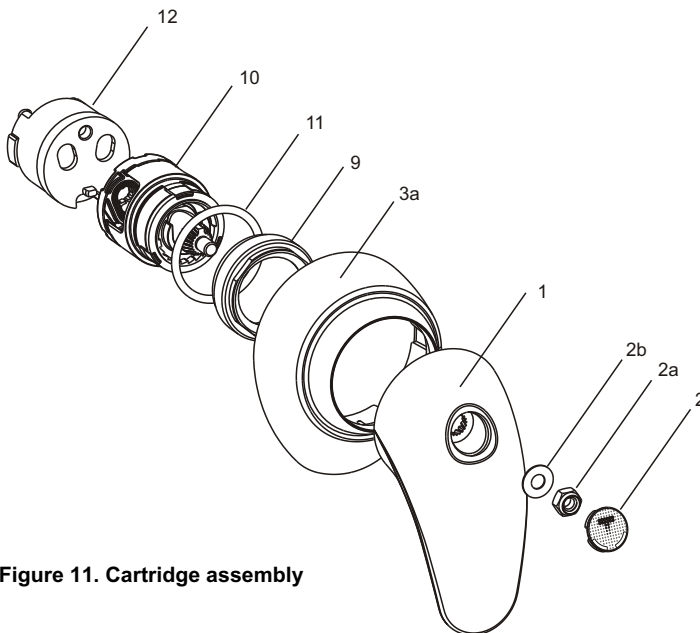
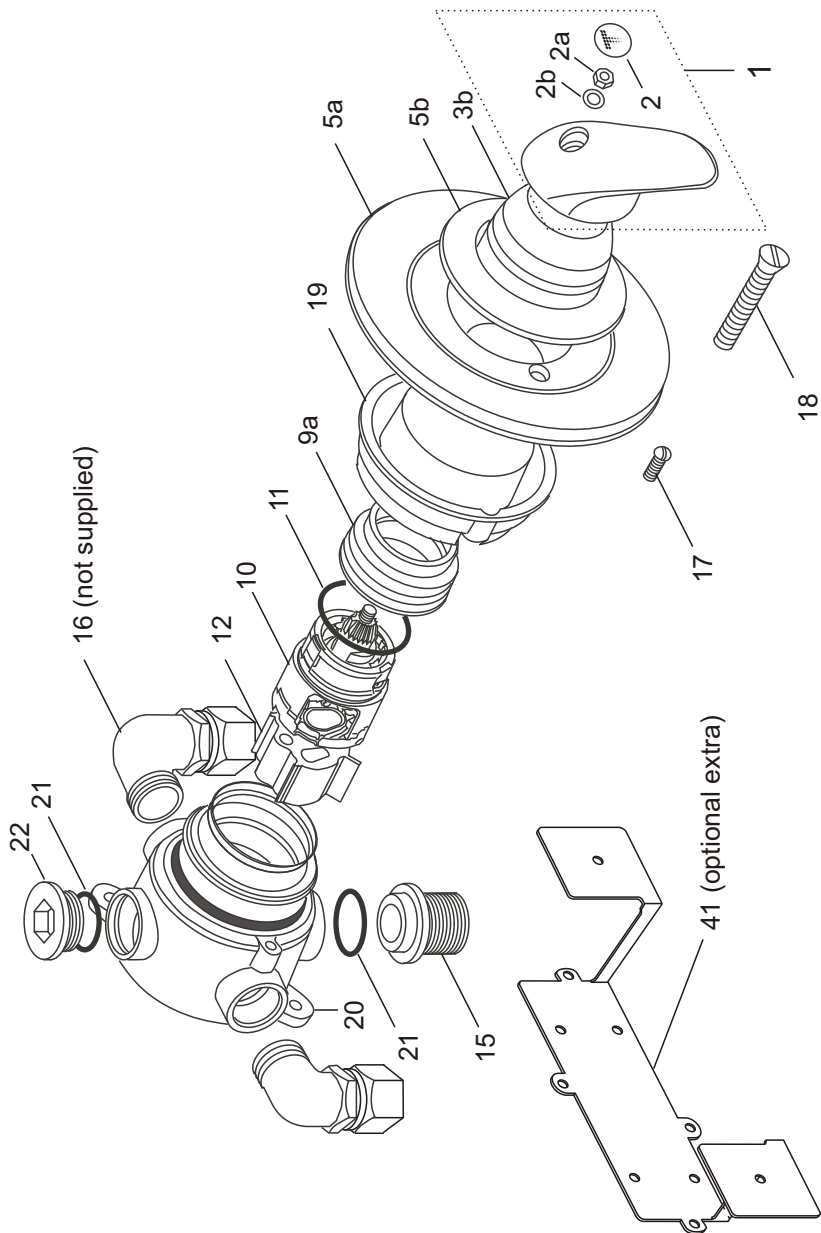
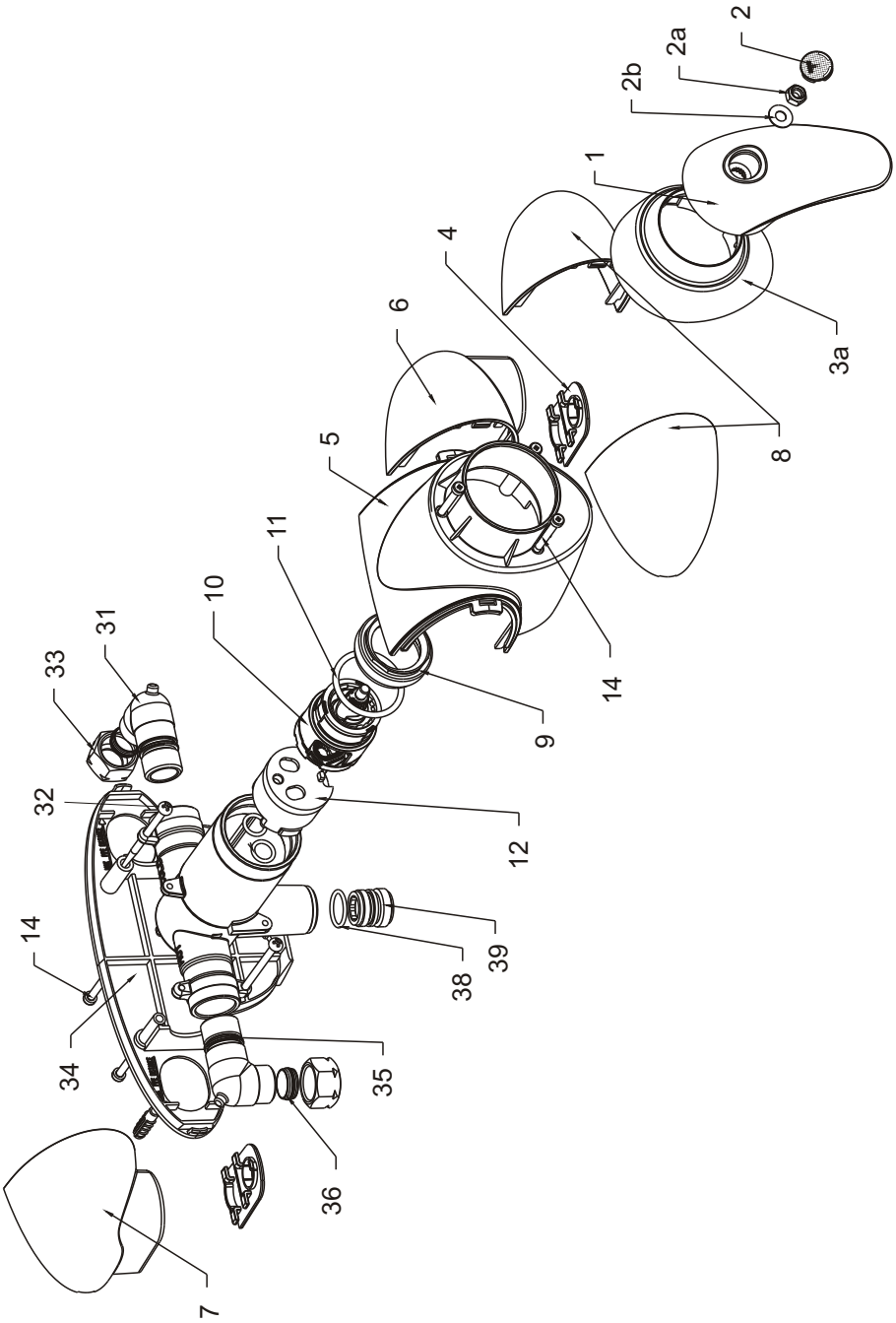

Figure 11. Cartridge assembly





Ref.	Description
1	Trevi Blend lever
2	Index button
2a	Nut
2b	Washer
3a	Shield (exposed)
3b	Shield (built-in)
4	CTV elbow cover pipe slip
5	CTV exposed cover body
5a	Built-in cover plate
5b	Built-in cover plate trim
6	CTV RH elbow cover
7	CTV LH elbow cover
8	CTV back inlet elbow cover
9	Exposed - cartridge locking ring
9a	Built-in cartridge locking ring
10	Multiport cartridge small
11	Cartridge sealing O-Ring
12	Multiport flow reversing moulding
14	Screw M4 25mm
15	Outlet nipple

Ref.	Description
16	Compression connector (not supplied)
17	Plaster guard retaining screw
18	Cover plate fixing screw
19	Plaster guard
20	Mounting lug
21	O-ring
22	Blanking plug
31	Sliding connecting elbow
32	Rear cover plate fixing screw
33	15mm compression nut
34	CTV exposed back plate
35	O ring
36	15mm compression olive
38	O ring
39	CTV size 1/2 outlet nipple
40	10 mm A/F box spanner
40	Cavity wall mounting bracket

Optional Extra

41	Cavity wall mounting bracket # L6714NU
----	---



TREVI

by Ideal-Standard

Trevi Showers
The Bathroom Works
National Avenue
Kingston-upon-Hull
HU5 4HS
England

CUSTOMER CARE HELPLINE

0870 129 6086

CUSTOMER CARE FAX

01482 499611

E-MAIL

ukcustcare@aseur.com

Trevi Showers pursues a policy of continuing improvement in design and performance of its products.

The right is therefore reserved to vary specification without notice.

Trevi Showers is a division of
American Standard Plumbing (UK) Ltd

T108 05/03

E96518100