

*Armitage  
Shanks*

**Lever operated sequential thermostatic  
monobloc basin mixer tap demountable**

**INSTALLATION  
INSTRUCTIONS**

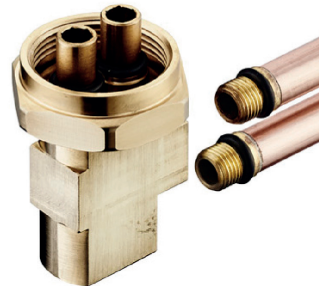

**A6791NU** Markwik 21+  
Back to wall connecting kit  
for closed wash basins

**A6696AA** Markwik 21+ thermostatic basin mixer with copper inlet pipes. Includes demountable body, removable spout & Bioguard outlet

**IMPORTANT**  
BEFORE CONNECTION, FLUSH WATER THROUGH PIPEWORK TO REMOVE ALL DEBRIS ETC. WHICH COULD DAMAGE THE VALVE MECHANISM

**INSTALLER:** After installation please pass this instruction booklet to user

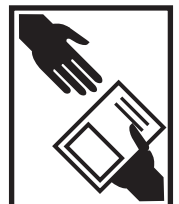

# TABLE OF CONTENT

<b>1</b>	<b>TABLE OF CONTENT</b> .....	<b>2</b>
<b>2</b>	<b>PRODUCT DESCRIPTIONS</b> .....	<b>3</b>
<b>3</b>	<b>PRODUCT DIMENSIONS</b> .....	<b>4</b>
<b>4</b>	<b>PRODUCT BOX CONTENTS</b> .....	<b>5</b>
<b>5</b>	<b>WATER SUPPLY CONDITIONS</b> .....	<b>6</b>
5.1	INTRODUCTION .....	6
5.2	SUPPLY PRESSURE REQUIREMENTS .....	6
5.3	HEALTHCARE ESTABLISHMENTS.....	6
<b>6</b>	<b>INSTALLATION</b> .....	<b>7</b>
6.1	FIXATION CONVENTIONAL WASH BASIN.....	7
6.2	CONNECTION TO SUPPLY PIPES .....	8
6.3	FIXATION CLOSED WASH BASIN .....	9
<b>7</b>	<b>OPERATION</b> .....	<b>11</b>
<b>8</b>	<b>COMMISSIONING &amp; AUDITS</b> .....	<b>11</b>
8.1	THE PURPOSE OF COMMISSIONING:.....	11
8.2	COMMISSIONING PROCESS (SEE DECISION TREE FC1).....	12
8.3	AUDIT CHECKS ON TMV'S.....	13
8.4	AUDIT PROCEDURE .....	14
8.5	IN-FIELD 'COLD WATER ISOLATION'(CWI) TEST .....	14
<b>9</b>	<b>SERVICING - TVM3 SCHEME</b> .....	<b>15</b>
9.1	FREQUENCY OF REGULAR SERVICING .....	15
<b>10</b>	<b>MAINTENANCE</b> .....	<b>16</b>
10.0	HANDLE REMOVAL.....	16
10.1	ADJUSTMENT OF THE MIXED TEMPERATURE .....	17
10.2	THERMAL SHOCK.....	17
10.3	INTEGRAL ISOLATION VALVES .....	18
10.4	REMOVAL & INSPECTION OF CARTRIDGE .....	18
10.5	IMPORTANT NOTES ON DEBRIS.....	19
10.6	THERMOSTATIC CARTRIDGE AGEING.....	19
10.7	ARMITAGE BIOGUARD OUTLET.....	20
10.8	OUTLET CLEANING .....	20
10.9	SPOUT REMOVAL .....	20
10.10	DEMOUNTING MIXER.....	22
10.11	DISINFECTION SOLUTION.....	23
10.12	INTEGRAL STRAINERS, CV-FR & SAFETY VALVES.....	23
<b>11</b>	<b>SPARE PARTS A6791NU</b> .....	<b>25</b>
<b>12</b>	<b>SPARE PARTS A6696AA</b> .....	<b>26</b>
<b>13</b>	<b>SPARE PARTS LIST</b> .....	<b>27</b>
<b>14</b>	<b>CLEANING CHROME SURFACES</b> .....	<b>28</b>

**The fittings covered by this installation and maintenance instruction should be installed in accordance with the water regulations published in 1999\*, therefore Armitage Shanks would strongly recommend that these fittings are installed by a professional installer**

\*A guide to the Water Supply (Water Fittings) Regulations 1999 and the Water Byelaws 2000, Scotland is published by WRAS (Water Regulations Advisory Scheme)  
Unit 13, Willow Road, Pen-y-Fan Industrial Estate, Crumlin, Gwent,  
NP11 4EG. ISBN 0-9539708-0-9

## 2 PRODUCT DESCRIPTIONS

**A6696AA**      **Markwik 21+ sequential lever operated thermostatic monobloc mixer tap with copper inlet pipes. Includes demountable body, removable spout & Bioguard outlet.**

**A6791NU**      **Markwik 21+ back to wall connecting kit for closed wash basins**

This manual covers product **A6696AA** which is a thermostatically controlled, lever operated sequential mixing tap. The mixer is designed to provide water from ambient cold up to a safe maximum temperature for hand washing.

This product is intended to be installed on single hole or two tap hole washbasins with a tap hole size of Ø30 to Ø36mm. Maximum ware thickness of up to 45mm.

The second product **A6791NU** (connecting kit) is sold separately & should only be purchased if the A6696AA mixer is being mounted on a **closed wash basin**. These basins are often used in healthcare environments where the underside of the wash basin has a smooth surface permitting it to be easily wiped clean. This type of wash basin has no opening on the underside for entry of water supplying pipe-work, therefore pipes enter the wash basin cavity from the rear.

A6791NU is effectively a 90° elbow which permits the copper inlet pipes supplied from the rear of the wash basin to be connected directly to the tail of A6696AA within the hollow cavity of the wash basin.

### **Product features A6696AA:**

The product body & spout are brass components with a durable chrome plated finish.

The robust mounting kit includes a brass clamping ring & three stainless steel locking screws.

The product is supplied with M10 rigid copper inlet pipes. Straight compression couplers are also included which permit direct connection to Ø15mm supply pipes.

The thermostatic cartridge is constructed from predominantly brass components for increased resistance to bacteria (organic polymer content reduced). Strainers are integral to this thermostatic valve with easy access for removal & cleaning. The product is provided with a facility for the thermal disinfection of the mixed water outlet.

The hot water chamber is thermally insulated to ensure the mixer body surface is maintained at a safe temperature when the product is in operation.

The base of this product is fitted with integral isolating valves, this permits the water supplies to be shut off thus allowing the mixer body to be demounted from the base. Once demounted, the body can be cleaned or disinfected. Safety valves integral to the base will prevent water spillage in the event that isolating valves have not been shut off. With the base exposed, this gives access to safety valves, strainers, combined check valves regulators. Maintenance work can be done without the need to gain access to the underside of the wash basin

It has been established that certain designs of outlet devices harbor planktonic bacteria, thereby encouraging the development of bio film & the bacteria colonisation process.

Armitage Bioguard outlet replaces the traditional flow straightener with a fully open copper-lined waterway. This greatly reduces the risk of bacteria build-up, whilst the copper lining has natural anti-microbial properties.



The spout can also be quickly & easily removed from the mixer body for cleaning or disinfection.

These products are air tested (dry) at the factory prior to packing (water is not used).

### 3 PRODUCT DIMENSIONS

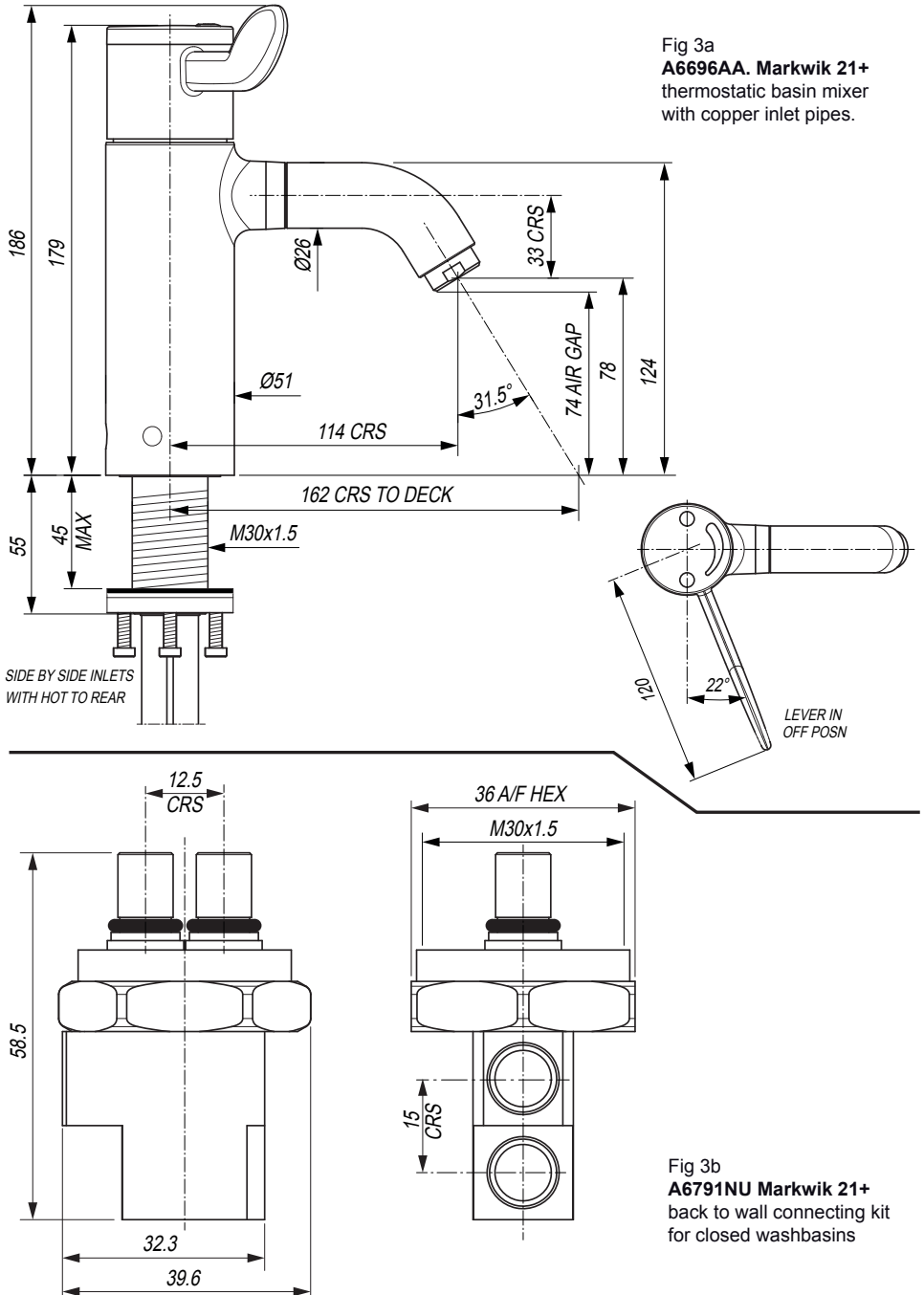

# 4 PRODUCT BOX CONTENTS

Pair of M10 copper inlet pipes x370 long, with O-ring seals.

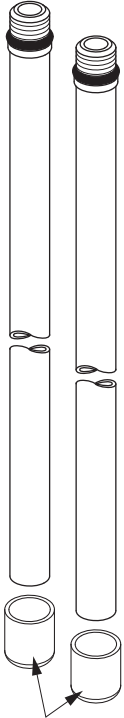

Protective end caps

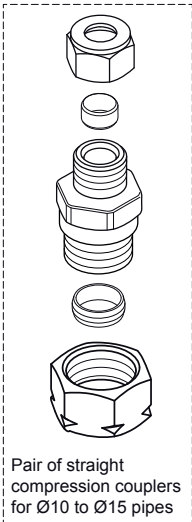

Pair of straight compression couplers for Ø10 to Ø15 pipes

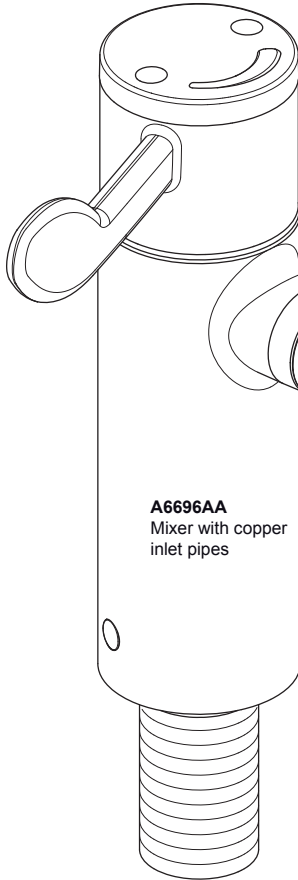

**A6696AA**  
Mixer with copper inlet pipes

Fig 4 Parts supplied



Override tool for thermal shock/ disinfection

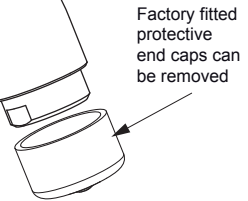

Factory fitted protective end caps can be removed



Mixer seal (flat washer type) for above the wash basin

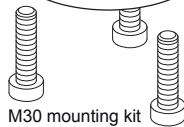
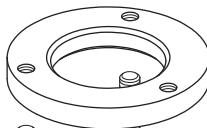

M30 mounting kit & wash basin seals.

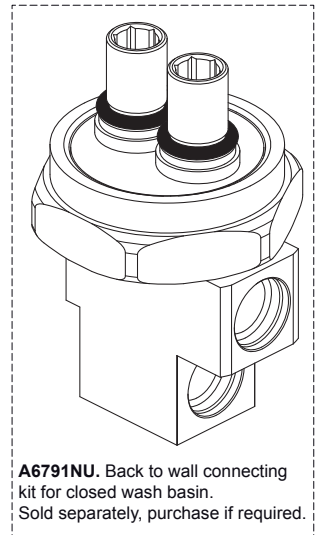

**A6791NU.** Back to wall connecting kit for closed wash basin. Sold separately, purchase if required.

# 5 WATER SUPPLY CONDITIONS

## 5.1 Introduction

This sequential thermostatic lever operated mixer is manufactured to the highest standards and has approval to TMV3 which permits it to be installed in healthcare establishments such as hospitals, nursing homes and residential care homes. When installed in healthcare establishments the supply conditions detailed in Table 1 must be observed and the commissioning and servicing requirements detailed on section 8 & 9 must be followed.

For other installations this is not a requirement.

## 5.2 Supply Pressure Requirements

This mixer is designed to be installed on all types of plumbing systems.

Hot and cold water supply pressures should be reasonably balanced, however, the mixer will function within specification on unequal pressures up to 5 :1.

The mixer has integral isolating valves which permit servicing of the strainer, combined check valve regulator & thermostatic cartridge. They are also used for Cold water isolation testing.

The minimum pressure for the correct thermal operation is 0.6 bar.

## 5.3 Healthcare Establishments

In accordance with the NHS model engineering specifications DO8 this valve has approval for the following applications:

High Pressure	HP-	-WE
Low Pressure	LP-	-WE

For this type of application the following supply conditions must apply:

Operating pressure range:	High Pressure	Low Pressure
Maximum static pressure	10 bar	10 bar
Flow pressure hot and cold	1 to 5.0 bar	0.6 to 1.0 bar
Hot supply temperature	55 to 65 °C	55 to 65 °C
Cold supply temperature	5 to 20 °C	5 to 20 °C

**Note:**

Fittings operating outside these conditions cannot be guaranteed by the scheme to operate as **TMV3**.

**Table 1 Supply conditions for healthcare establishments**

Effectively this means:

Differential between HOT and COLD inlet temperatures (  $\Delta t$  ) must be 35C° min and 60C° max

Differential between HOT inlet temperature and MIXED temperature (  $\Delta t$  ) > 14C° preferred

**See 8.3 Audit checks on TMV's.**

# 6 INSTALLATION

## PRE-INSTALLATION INFORMATION

Avoid using heat for soldering near the product inlets, to prevent damage to internal components.



**IMPORTANT:** Ensure that any old / existing thermostatic mixing valves (TMVs) that may be fitted in the supply pipes are removed

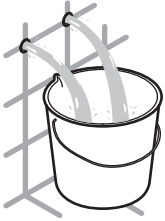

**IMPORTANT NOTE:**  
Before connecting the product, it is strongly recommended to flush the supply pipe-work to remove any plumbing residues or debris remaining after installation

### 6.1 FIXATION conventional wash basin

Where water supply pipes can enter the wash basin cavity conventionally from the underside. NOTE: The mixer can be prefixed to the wash basin before the basin is mounted to the wall.

**These products are supplied with a clamping ring kit, which allows stronger fixation to the ware.**

1. Insert the mixer into the basin tap hole - ensuring that the basin seal is correctly seated in the groove on the underside of the mixer body. Allow the mixer to rest on top of the basin.

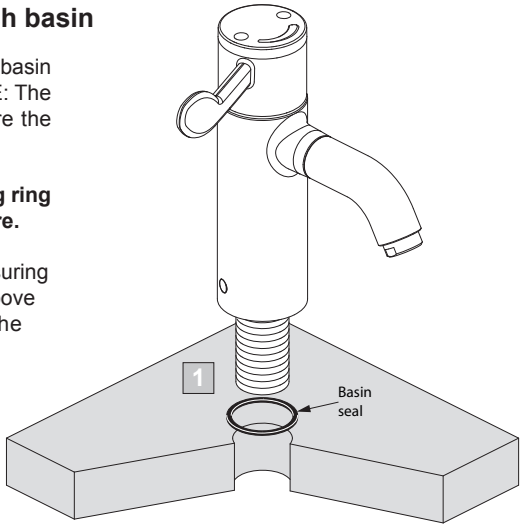
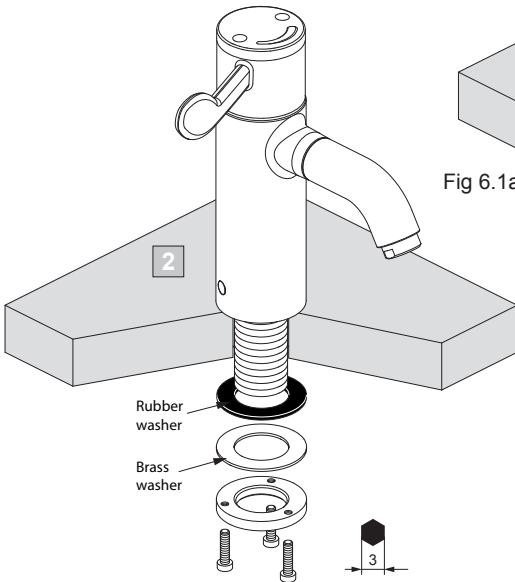
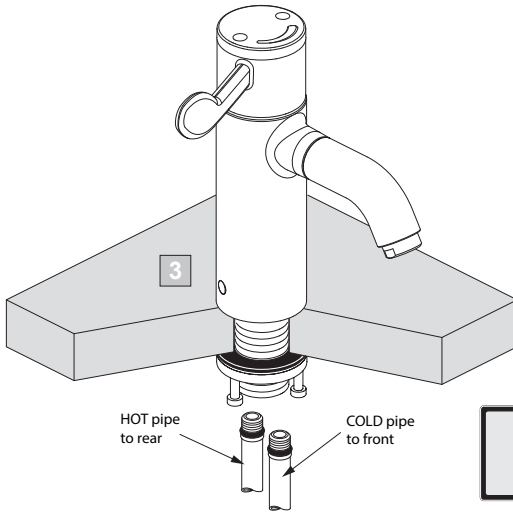

Fig 6.1a Mounting to basin

2. Slide the rubber washer onto the tail followed by the brass washer. It is important that the rubber washer is seated against the underside of the basin. Screw the clamping ring onto the tail until it contacts the brass washer which in turn squeezes the rubber washer against the basin. Ensure that the spout of the mixer is correctly aligned in the basin.

Tighten the three screws using a 3mm hexagonal key, until the mixer is securely mounted to the basin. Be careful not to over tighten screws as this could damage the basin.



3. Screw-in the copper inlet pipes into the bottom of the mixer tail. (The copper pipes may be fitted to the mixer before inserting into the tap hole). Ensure the O-rings are in position on the inlets – hand tightening the inlets into the mixer is sufficient to achieve a water tight seal.



**NOTE: THE INLET HOLE AT THE FRONT OF THE MIXER TAIL IS FOR COLD WATER & THE REAR INLET HOLE IS FOR HOT WATER.**

Fig 6.1b Connecting inlet pipes

## 6.2 Connection to supply pipes

A pair of straight couplers are supplied with the mixer to enable both of the  $\varnothing 10\text{mm}$  copper inlet pipes of the mixer to be connected to conventional  $\varnothing 15\text{mm}$  water supply pipes. If necessary, carefully trim the copper inlet pipes to suit installation & make-good the ends.

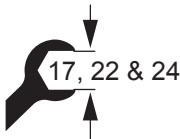

**NOTE FOR IRELAND: 15mm olives are supplied with this product. Use 1/2" olives if 1/2" supply pipes are fitted.**

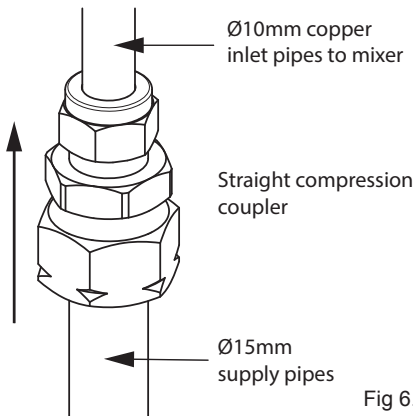

### Compression joint

Use this procedure for both  $\varnothing 15$  &  $\varnothing 10$  pipes:

- Dismantle the straight coupler.
- Slide the nut onto the pipe.
- Then slide the olive onto the pipe.
- Push the pipe into the coupler right up to the shouldered stop & hold in place.
- Slide the olive back against the coupler.
- Slide the nut towards the coupler & hand tighten.
- Hold the coupler with a 22mm A/F spanner & tighten the nut with a 17 or 24 A/F spanner.

**MAKE SURE ALL JOINTS ARE TIGHT THEN OPEN WATER SUPPLIES. CHECK FOR LEAKS.**

Fig 6.2 Pipe connecting



### 6.3 FIXATION closed wash basin

**A6791NU** (connecting kit) is sold separately & should be purchased if the A6696AA mixer is being mounted on a **closed wash basin**. These basins are often used in healthcare environments where the underside of the wash basin has a smooth surface permitting it to be easily wiped clean. This type of wash basin has no opening on the underside for entry of water supplying pipework, therefore pipes enter the wash basin cavity from the rear.

A6791NU is effectively a 90° elbow which permits the copper inlet pipes supplied from the rear of the wash basin to be connected directed to the tail of A6696AA within the hollow cavity of the wash basin.

**NOTE:** The mixer can be prefixed to this type of wash basin before the basin is mounted to the wall. Carry out steps 1 & 2 from section 6.1 for mounting to a conventional wash basin.

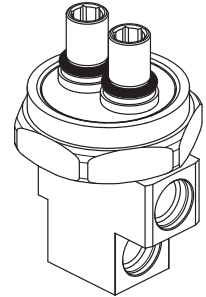

Fig 6.3a A6791NU as supplied.

A6791NU connecting kit is supplied fully assembled & is ready to install.

- Check that both O-rings are in place on the nipples at the top of the connecting kit.
- Ensure the two bores in the connecting kit are facing towards the supplying pipes (to rear of wash basin).
- Align the two nipples to the two bores in the bottom of the mixer tail.
- Slide the two nipples into the bores, press connector firmly to ensure O-ring on the nipples are engaged into the mixer tail bores.

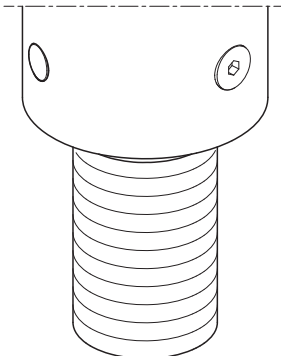

Fig 6.3b Insert connector into tail

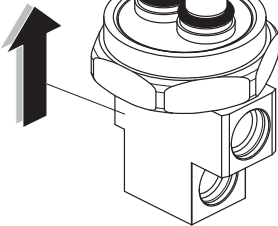

Fig 6.3c Nut tightened up



- Slide the M30 captive nut towards the tail & fully screw onto tail by hand.
- Use a large adjustable spanner to tighten the captive nut (36mm A/F). **NOTE:** Excessive force is not necessary.

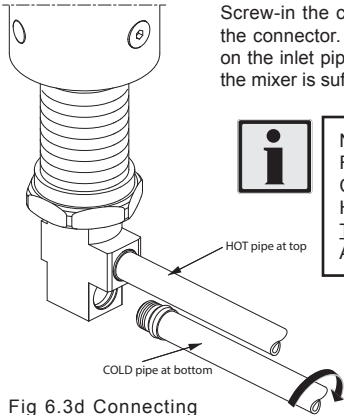

Fig 6.3d Connecting inlet pipes

Screw-in the copper inlet pipes into the ports of the connector. Ensure the O-rings are in position on the inlet pipes – hand tightening the inlets into the mixer is sufficient to achieve a water tight seal.



**NOTE: THE INLET HOLE AT THE FRONT OF THE MIXER TAIL IS FOR COLD WATER & THE REAR INLET HOLE IS FOR HOT WATER. THE CONNECTOR PORTS ARE: HOT AT THE TOP & COLD AT THE BOTTOM.**

### Connection to supply pipes

Refer to the previous section 6.2 for connecting straight couplers to the water supplies.

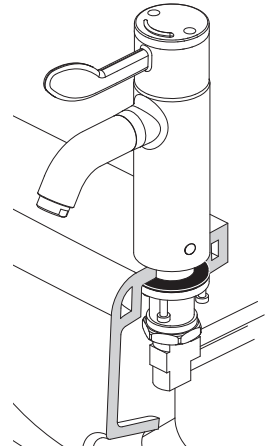

Fig 6.3e Example of mixer mounted in a **centre tap hole** in a closed wash basin

### Mounting mixer into an off-centre tap hole

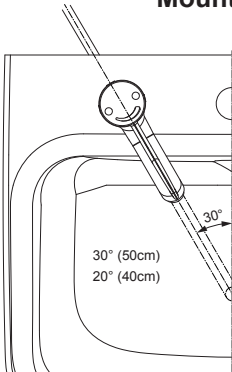

Fig 6.3f Plan view showing mixer mounted at 30° into left hand tap hole of a **50cm Contour 21+** wash basin. **FOR 40CM BASIN WASH USE 20° ANGLE.**

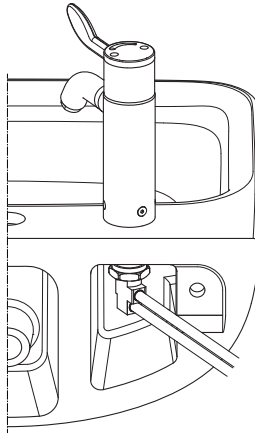

Fig 6.3g Rear view showing wash basin with mixer pre-fitted into left hand tap hole.

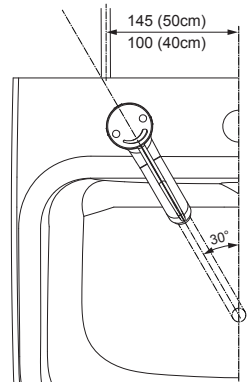

Fig 6.3h Plan view showing copper pipes bent 145 for 50cm wash basin centre line. **FOR 40CM WASH BASIN BEND TO 100.**

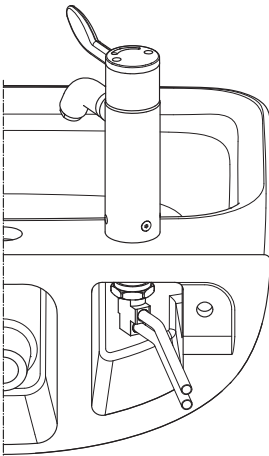

Fig 6.3i Rear view showing copper pipes bent to 145 position on 50cm wash basin.

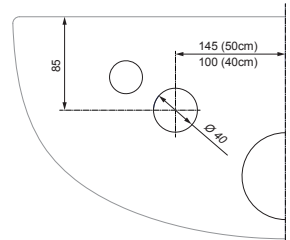
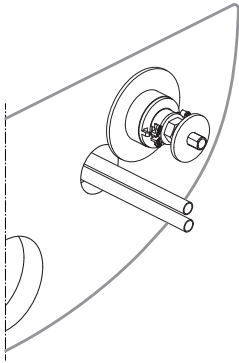

Fig 6.3j Front view of panel showing hole position at 145 for copper pipes, for 50cm wash basin with left hand tap hole. **DRILL AT 100 CENTRES FOR 40CM WASH BASIN**



MIRROR HOLE POSITION  
IN PANEL FOR RIGHT HAND  
TAP HOLE WASH BASIN

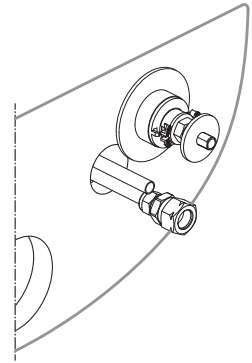

Fig 6.3k Rear view of panel with wash basin mounted. Hole shown for copper pipes. Trim pipes to length.

Fig 6.3m Rear view of panel shown with pipe coupler fitted. Alternatively elbows can be used.

## 7 OPERATION



Fig.7 showing the handle control positions. As the handle is rotated anti-clockwise from the off position the delivered water progresses from cold through warm to the preset maximum temperature of approximately 41°C.

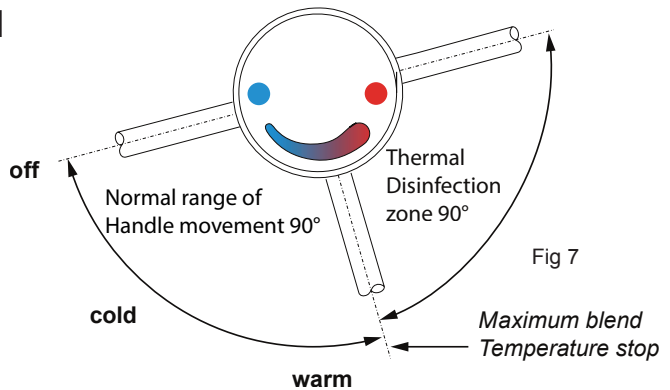

Fig 7

NOTE: The thermal disinfection zone shown above is only available if activated by thermal override tool, see section 10.2

When installed as a TMV3 application it is requirement that the commissioning and maintenance procedures detailed here be carried out. For non-healthcare installations these checks are not required.

## 8 COMMISSIONING & AUDITS

The following procedure should be conducted after installation to ensure the product is functioning correctly.

### 8.1 The Purpose of Commissioning:

- To confirm the correct designation of product versus application.
- To confirm the correct supply water conditions for the product / installation.
- To adjust the mixed temperature if necessary to suit the water supply conditions of the installation.
- To check the product is performing properly.
- To start an audit log and record appropriate data.

These products are factory set at 40°C ± 1°C with supplies of circa; 3 bar balanced pressure and temperatures of 15°C cold & 65°C hot (i.e. an inlet  $\Delta t$  of 50°C & hot / mix  $\Delta t$  of 24°C)  
For supply requirements, see 5 Water Supply Conditions.

## 8.2 Commissioning Process (see decision tree FC1)

- Establish that the supply conditions are within the requirements outlined in 8.1. If not investigate.
- When conditions are acceptable record them, together with hot and cold temperatures. Establish  $\Delta t$ .

Check the outlet mix temperature is within  $41^{\circ}\text{C} \pm 2^{\circ}\text{C}$ , if not (probably due to  $\Delta t > 5^{\circ}\text{C}$  difference to factory setting) adjust appropriately. (see section 10.1)

- If mixed temperature is correct undertake an 'in field' cold water isolation (CWI) test: (see section 8.5)
  - Pass - restore supply and record mixed temperature,
  - Fail - See 8.5 in-field 'Cold Water Isolation' test.

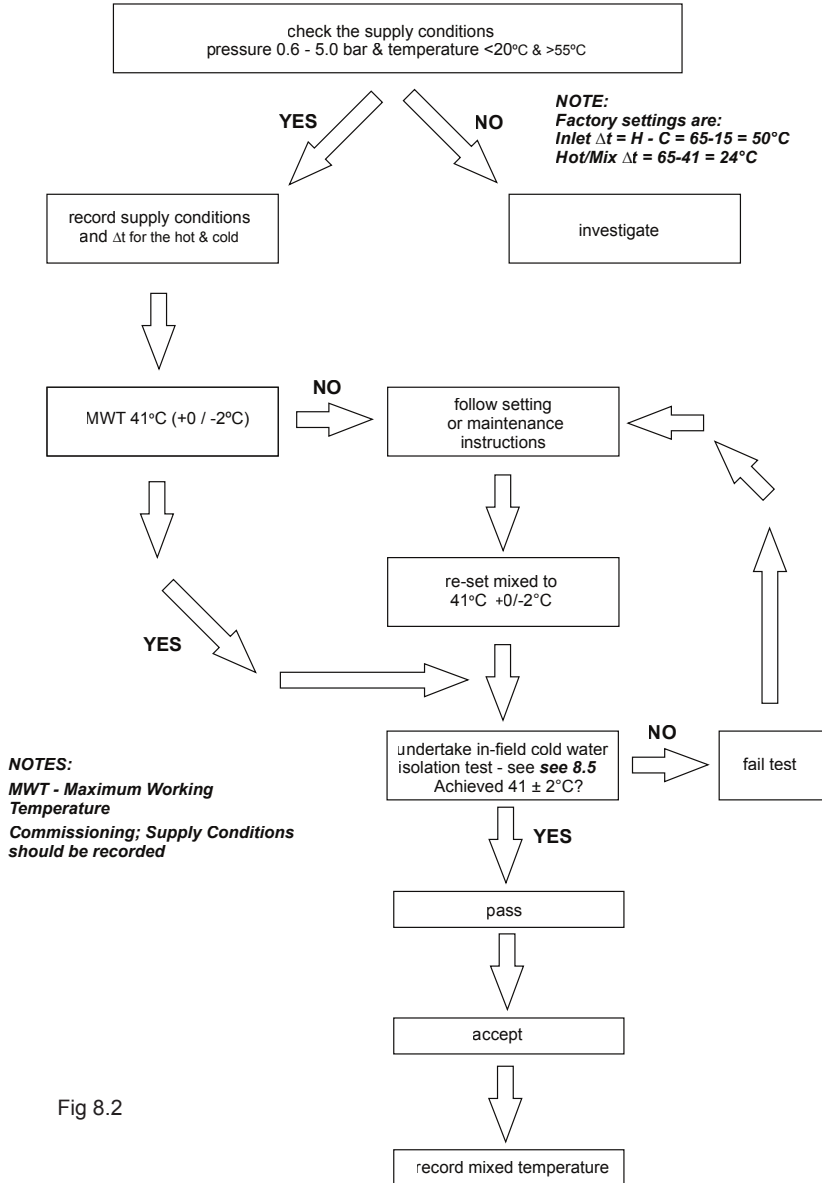

Fig 8.2

### 8.3 Audit Checks on TMV's

The purpose of a performance audit of a product is:

- ♦ To check the product continues to perform properly.
- ♦ To flag the need for the product to be adjusted due to supply condition changes or mechanism ageing.
- ♦ To ultimately identify the need for product maintenance.

*Note - Additionally these audits facilitate regular verification of the supply conditions in accordance with HTM 04 requirements. (See decision tree FC3)*

#### Audit of Supplies To Fittings (FC3)

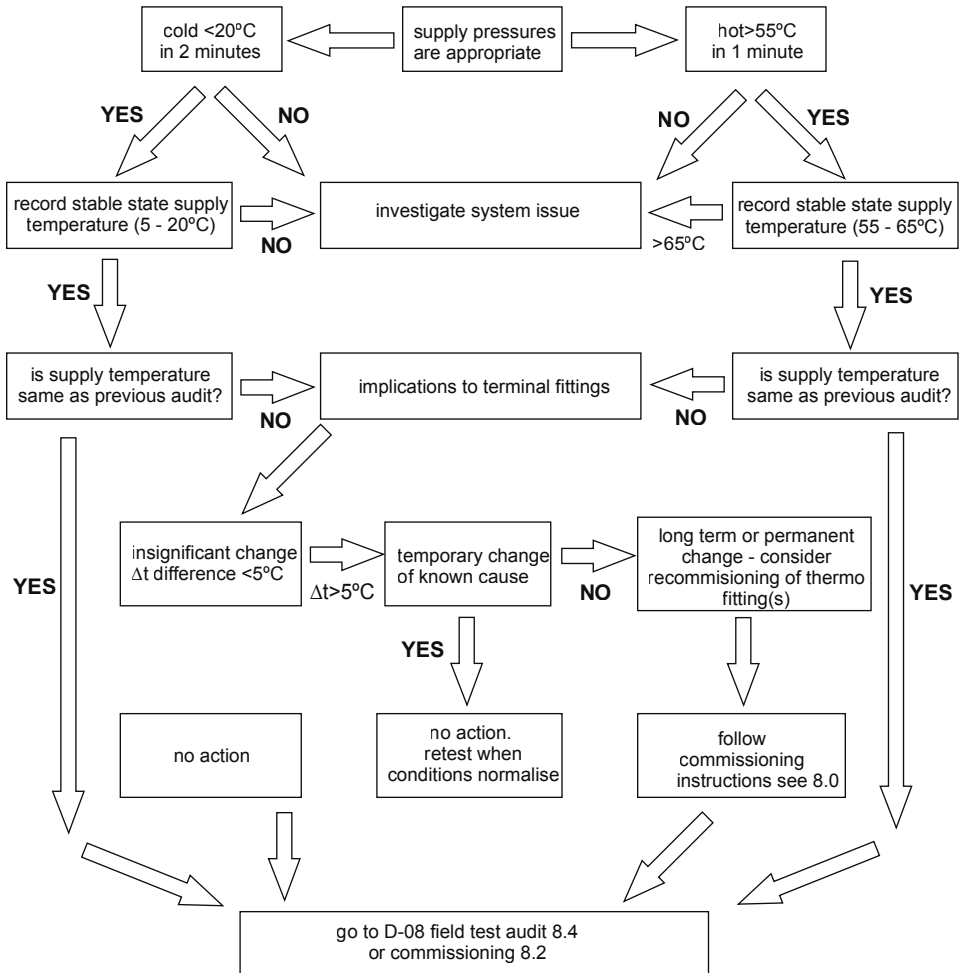

Fig 8.3

## 8.4 Audit procedure (see decision tree FC2)

- Verify the water supplies conditions are similar to when the product was commissioned i.e. inlet  $\Delta t$  as previous  $\pm 5^\circ\text{C}$

*Note: If inlet  $\Delta t$  change is  $> 5^\circ\text{C}$  consider the cause of the change, if it is seen as a long term or permanent change, re-commission the product. If however, it is only a temporary change, retest when normal conditions resume.*

- If inlet  $\Delta t$  differs from the commissioning  $\Delta t$  by  $< 5^\circ\text{C}$  carry out field 'cold water isolation' (CWI) test as D-08: 2009. (see 8.5 in field **Cold Water Isolation test failure.**)
- Pass - restore the cold supply and move on to check the mix temperature.

*Note: If the product fails CWI test, refer to 8.5 and then re-commission the valve.*

- Mixed Temperature is as commissioned  $\pm 2^\circ\text{C}$ , Accept and record the temperature.

*Note: If mixed Deviation  $> \pm 2^\circ\text{C}$  (1st instance) reset mix as instructions and redo the test from start. See 10.1 Adjustment of the mix temperature.*

- 2nd & subsequent instances follow maintenance instructions.

## Fitting Field Test Audit (FC2)

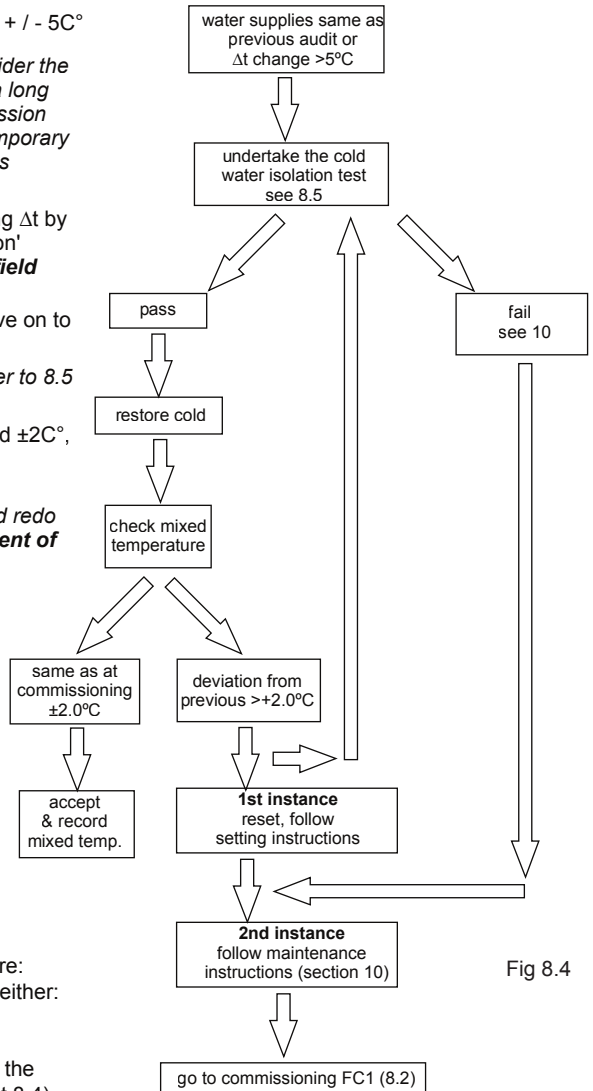

Fig 8.4

## 8.5 In-field 'Cold Water Isolation' (CWI) test.

Before commencing the CWI test, ensure:

- The water supply conditions are met either:
  - For commissioning a new product (See table 1, section 5.3)
  - Or the inlet  $\Delta t$  is within  $\pm 5^\circ\text{C}$  to when the product was commissioned (see sect 8.4).

**NOTE: It is important that the hot temperature is greater than  $55^\circ\text{C}$**

- Mixed water outlet temperature is correct (see table 2, section 9).
- Use a blade to remove the grommet on the right hand side of the mixer (near the base)
  - Using a 5mm hexagonal key turn the cold isolating screw fully clockwise to isolate the cold water supply

To perform a CWI test, operate the product by rotating the lever fully to the right.

Then conduct the following procedure:

1. Record the steady state temperature of both hot and cold water supplies. Note the  $\Delta t$ .
2. Record the temperature of the mixed water at the outlet.
3. Isolate the cold water supply (by rotating the isolating screw fully clockwise) & monitor the flow of water from the outlet.

If the flow ceases, CWI test passed:

1. Restore the cold water supply by rotating the isolator screw 90° anti clockwise.
2. Re-check the temperature of the stabilised mixed water at the outlet to ensure it is still correct.

Accept & record mixed temperature.

If there is an ongoing flow of water from the mixed water outlet, then 5 seconds after CWI collect the discharging water into a measuring vessel for 60 seconds. To pass the CWI test the volume of collected water should be less than 120ml.

If the product fails CWI test, see FC2 (**see section 8.4**). Follow product maintenance (**see section 10**) and servicing (**see section 9**) instructions.

## 9 SERVICING - TVM3 SCHEME

The need for servicing is normally identified as a result of the regular performance auditing.

Application	Maximum mixed water temperature during normal operation	Permitted maximum stabilised temperature recorded during site testing – excluding transient spikes
Washbasin	41°C	43°C

**Table 2 A guide to maximum temperature sets**

### 9.1 FREQUENCY OF REGULAR SERVICING

The purpose of servicing regularly is to monitor any changes in performance due to changes in either the system or the product. This may highlight the need to adjust either the supply system or the product. These products should be audited 6 to 8 weeks and again 12 to 15 weeks after commissioning. The results are to be compared against original commissioning settings.

If the product passes the audit test three consecutive times (demonstrating good stability of system & product) then a 12 monthly servicing cycle may be adopted.

Otherwise, servicing checks should be carried out more frequently (e.g. every 4 months). Follow the recommended auditing and maintenance procedures detailed in sections 8 & 10.

During servicing, note the following:

1. Repeat the procedure of recording and checking supply temperatures. (The same type of measuring equipment should be used)
2. If the temperature has changed significantly from the previously recorded values, the following should be checked:
  - a. All in-line or integral valve filters are clear of obstruction.
  - b. All in-line or integral check valves are clean and working properly to prevent backflow.
  - c. All isolating valves (integral to service valve) are fully open.
  - d. The thermostat is free of debris
3. When satisfied with the mixed outlet temperatures re-record the temperatures.

# 10 MAINTENANCE

When installed in a TMV3 application, we recommend that the commissioning and maintenance procedures, detailed under 8 & 10, be carried out.

## 10.0 Handle removal

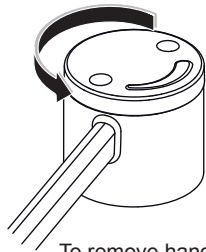

To remove handle:

- Twist the bayonet handle cap anti-clockwise & lift it off.
- Undo the retaining screw using a 4mm hexagonal key.
- The handle can now be lifted off the mixer.
- To refit the handle reverse this procedure, observe the alignment features shown below.

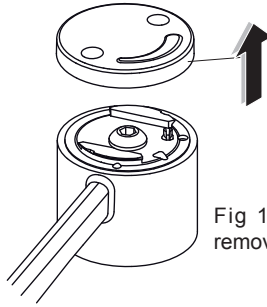
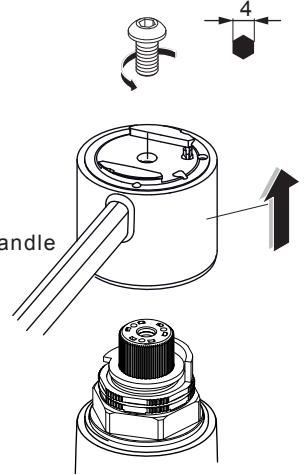

Fig 10.0a Handle removal



## Cartridge rotation stops

Two rotational stop rings are fitted to the cartridge.

The inner metal spindle stop ring sets the clockwise off position and the outer polymer ring sets the anticlockwise maximum blend temperature and also provides the thermal override feature.

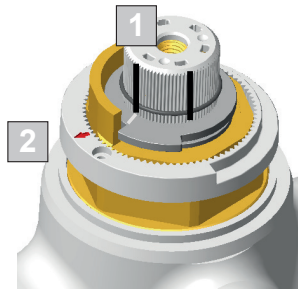

1

Fully clockwise off position. Tab of the inner metal stop ring aligns with left black line printed on the cartridge spindle. There is a line on the stop ring to assist alignment.

2

Position of the outer white polymer temperature stop ring shown at 40°C with the red arrow at the 9 o'clock position facing left.

Removal of these rings is not necessary for handle fixation. However the outer white polymer ring can be rotated when temperature adjustment proves necessary. Clockwise to reduce or anticlockwise to increase the maximum blend temperature.



**IMPORTANT!** Ensure tab of the inner metal stop ring is firmly against the clockwise rotation stop. If not, rotate the spindle clockwise until it is. The cartridge is now in the off position. If necessary, use the spline drive in the lever handle to rotate the spindle.

Fit the lever handle to the cartridge spindle with cut-out arrow at the 6 o'clock position facing forwards.

Fit the lever handle screw and tighten fully to a torque of 5 NM using a 4mm hexagon key.

Finally fit the bayonet cover cap to the lever handle.

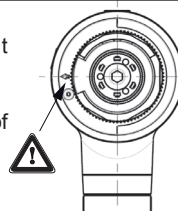

Lower ring alignment

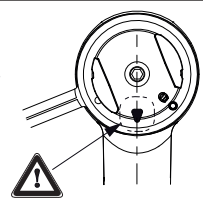

Handle alignment

**NOTE:** THE LOCATION OF THE CARTRIDGE "STOP-FACE" MAY NOT BE AS SHOWN ABOVE, ORIENTATION OF THIS FACE IS DEPENDENT ON THE CARTRIDGE THREAD.



## 10.1 Adjustment of the mixed temperature

**Note:** Cartridge is factory pre-set at  $40\pm 1^\circ\text{C}$  with pressure of 3 bar. With differing supply conditions, adjustment may be necessary to maintain this set temperature.

1. Move the lever to the fully on position (max anti-clockwise).  
Allow water to flow & check the temperature.
2. Remove the handle, see section 10.0
3. Lift off the lower stop ring (slide off cartridge). To adjust the max blend temperature, rotate this ring & refit to cartridge.  
Aim to achieve correct mix temperature of  $40\pm 1^\circ\text{C}$ .
  - To increase the temperature, rotate this ring anti-clockwise
  - To reduce the temperature rotate this ring clockwise.
4. Do not adjust the upper stop ring.
5. Rotate the cartridge spindle clockwise to off position (to stop), use the handle if necessary.
6. Replace & align handle, see section 10, move handle to the new full on position re-check the set temperature & if necessary repeat the adjustment sequence.

If you are unable to achieve  $40\pm 1^\circ\text{C}$  Max and you have the correct  $\Delta t$ 's it may be due to fine debris.

See section 10.4 **Removal and inspection of cartridge.**

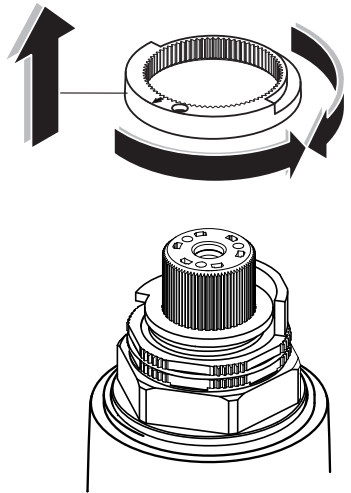

Fig 10.1  
Adjusting the preset temperature

7. Upon successful completion of the temperature adjustment, conduct the **Cold Water Isolation (CWI) test** (See section 8.5) to ensure product is working properly.
8. Refit the lever and record the mix temperature.

## 10.2 Thermal Shock

**Safety Note:** Care should be taken when carrying out the following procedure to avoid contact with hot water and hot surfaces.

For thermal disinfection, this fitting is equipped with a built in thermal shock feature. The tool supplied allows the maximum blend stop to be overridden. This allows hot water at “supply temperature” to flow through the mixer cartridge and permits thermal disinfection of the spout.

1. To activate, remove the handle cap, see section 10.0.
2. Screw the override tool fully into the threaded port on top of the handle, see fig 10.2a
3. Carefully lift the override tool and turn the handle fully anti-clockwise, hot water will be discharged.  
See fig 7, for thermal override range of handle movement.
4. See table below for a guide to disinfection temperatures verses time. Allow hot water to discharge from the mixer for appropriate period.
5. Once the thermal shock is complete, remove override tool, return the handle to off, and refit the cap. Check the mixer for normal operation to ensure it is functioning correctly.

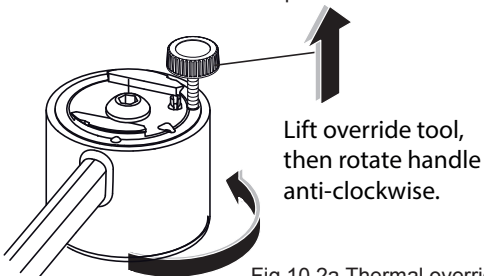

Fig 10.2a Thermal override tool

Temperature	Disinfection time
60°C	20 minutes
65°C	10 minutes
70°C	5 minutes

### 10.3 Integral isolation valves

The integral isolation valves facilitate a number of activities:

- Servicing the thermostatic cartridge
- Cleaning or replacing the strainers
- Audit Cold Water Isolation (CWI) test
- Demounting the mixer from its inlets
- Replacing the check valve flow regulator assemblies

To isolate the mixers, proceed as follows:

1. Remove the small grommets (grey buttons) at the base of the mixer (use a sharp blade if necessary, avoid damaging chromed surface of mixer).
2. Isolate both inlets by screwing isolation valves down fully using a 5mm hexagonal key in the clockwise direction. Operate the lever to confirm supplies are closed off.
3. Reverse procedure to restore the water supplies and refit the grommets.

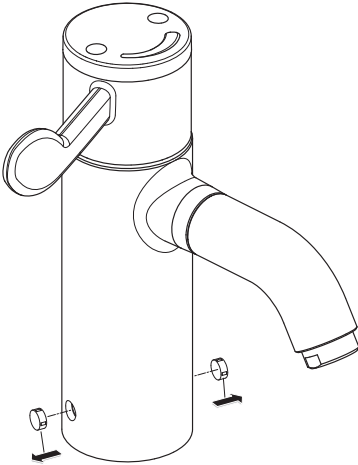

Fig 10.3a Remove grommets

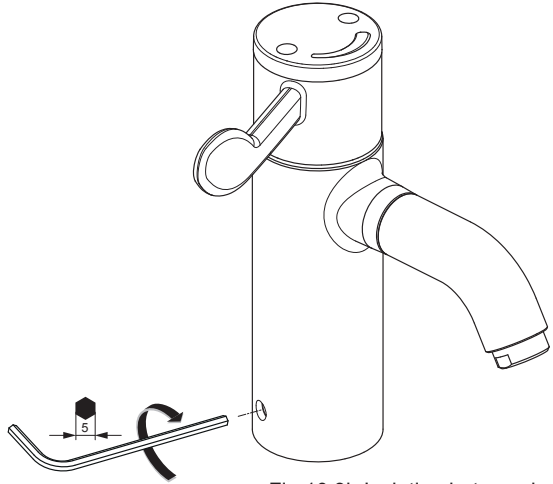

Fig 10.3b Isolating hot supply

NOTE: Isolating screw on the LEFT side of the mixer is for the HOT water supply & Isolating screw on the RIGHT side of the mixer is for the COLD water supply.

For Cold Water Isolation (CWI) test, close only the COLD supply (on right).

### 10.4 Removal & inspection of cartridge

After checking that supply conditions are within the specified parameters (see table 1, section 5.3), and if the mixer malfunctions or should the test results fail to fall within the specified limits consider replacing the cartridge with a new one. See sect. 10.5 **important notes on debris**

1. Isolate the fitting by closing the isolating valves, see section 10.3.
2. Remove the lever handle as described in section 10.0.
3. Lift off the lower stop ring.

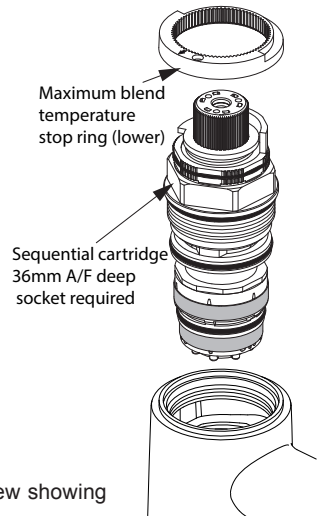

Fig 10.4 Exploded view showing sequential cartridge

4. Unscrew the cartridge from the body with a 36mm a/f deep socket. If necessary, to prevent the mixer rotating in the wash basin, hold the mixer spout to steady.
5. Wash the cartridge in clean water and inspect it for damage. The cartridge has integral strainers, these can be removed for cleaning & replaced if necessary.
6. Replace cartridge if necessary and reassemble cartridge into body.  
The replacement cartridge should be tightened to a torque of 15Nm. (To re-secure the cartridge we recommend the use of Permabond A011 or equivalent applied to the thread of the cartridge)
7. Replace the lower stop ring (see section 10.1). Refit the lever handle (see section 10.0) and reinstate the water supplies (see section 10.3)

After fitting the new cartridge start the test procedure from the section on commissioning.

- Conduct the Cold Water Isolation (CWI) test (See section 8.5).
- Once satisfied with the CWI test, re-check and if necessary, adjust the maximum mix temperature, see (See section 10.1).
- Record the mix temperature

NOTE: Replacement O-rings & strainers are available for this cartridge. See sections 12 & 13.
---

## 10.5 Important notes on debris

Although this product is protected by multiple strainers, debris can still find its way to the thermostat housing area. This can happen during servicing for example. Remove cartridge (see section 10.4) and carry out an inspection. The thermostatic cartridge has built-in strainers, these should be inspected & if necessary washed in clean water or replaced (see sections 12 & 13).

## 10.6 Thermostatic Cartridge Ageing

Following many years of normal service you may notice the following:

1. The need to carry out more frequent adjustment of mixed temperature.
2. The thermostatic element may not pass the CWI test.

These issues could be due to the ageing of the thermostat which loses some expansion capability over time.

These are the principle objectives of testing, as they serve to indicate to maintenance staff the declining performance capability of the thermostatic cartridge.

For this reason the audit testing flow chart highlights that 2nd Instance CWI test failure or 2nd instance mixed deviation even with stable 'as commissioned' supply conditions and correct inlet supply  $\Delta t$ 's, is potentially the first indication of the need to replace the cartridge.

## 10.7 Armitage Bioguard Outlet

Traditional “flow straightener” type outlets have recently been identified by extensive research as an area most likely to harbour bacteria. This product uses an Armitage Bioguard outlet which replaces this traditional flow straightener with a fully open copper-lined waterway. This greatly reduces the risk of bacteria build-up whilst the copper lining has natural anti-microbial properties.

Outlet is suitable for autoclaving.

In the interests of infection control and health hygiene, the Armitage Bioguard Outlet is a supplement to, not a substitute for, standard infection control practices. Continue to follow all current protocols, including those practices related to cleaning and disinfection of surfaces. Refer to HTM04-01 for more details.

*Patent pending for Armitage Bioguard antibacterial outlet, application No: 10 2012 107 243.4*

**OUTLET Strainer: The Armitage Bioguard outlet can be removed (as described below) & replaced with a universal filter adaptor, A6256AA (contact Customer Care). The adaptor will accept most types which are externally threaded M24x1.**

## 10.8 Outlet cleaning

On a regular basis the outlet should be inspected and cleaned.

Note: Lime scale deposits should be removed prior to using any disinfection treatments.

To unscrew and remove the outlet, use an adjustable spanner on the flats (20mm). To refit, hand tighten and then use the spanner until the outlet has bottomed in the bore. Take care not to over tighten.

In areas where lime scale build-up is prevalent this should be avoided by regular cleaning. If it should build up, it will have to be removed. An inhibited proprietary scale solvent can be used such a kettle descaling solvent but it is important to follow the manufacturer’s guidelines. After descaling it is important to rinse the parts thoroughly in clean water. Clean carefully and do not use abrasive materials or scrapers

## 10.9 Spout removal

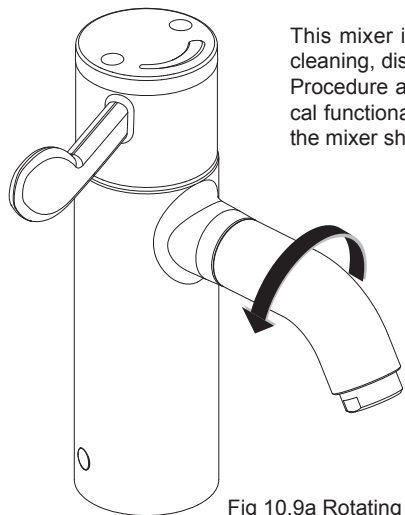

This mixer is fitted with a quick easily removable spout to assist with cleaning, disinfection by immersion or sterilisation by autoclaving. Procedure assumes availability of a replacement spout. For both practical functional reasons along with environmental contamination reasons, the mixer should not be left without a spout fitted in place

1. Ensure the handle is in the off position.  
To remove the spout: gently rotate the end of the spout anticlockwise by 90°.

Fig 10.9a Rotating the spout

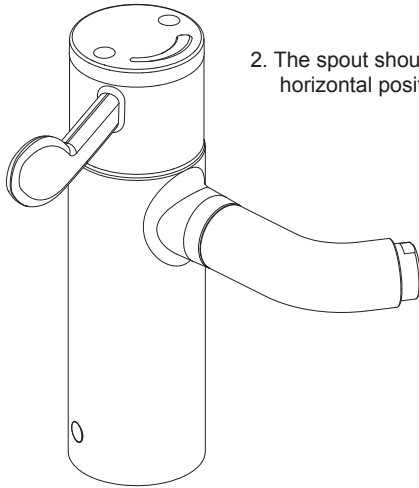

2. The spout should now be in the horizontal position as shown.

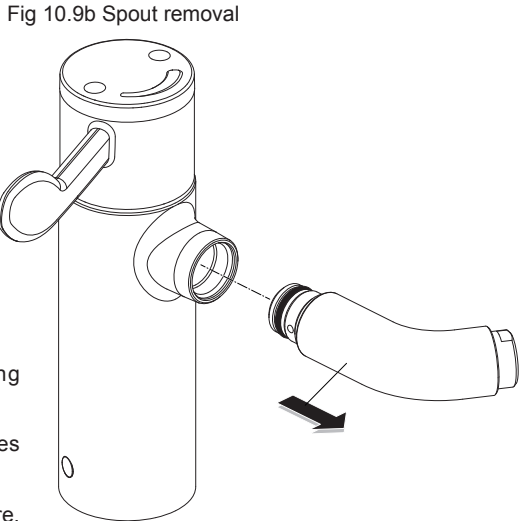

Fig 10.9b Spout removal

3. Gently pull the spout away from the body as shown.

Quarantine this spout for cleaning protocols.

Ensure replacement spout complies with cleaning protocols.

To refit a spout, reverse this procedure.



**IMPORTANT:**  
Do not leave the mixer outlet open without a spout fitted.

### Spare spouts

Additional spouts are available so during cleaning protocols an alternative spout can be fitted while the original is removed. This insures continuity of use of the mixer. For additional spout part numbers, see section 12 & 13.

### Cleaning / disinfecting / sterilising the removed spout.

Physical **cleaning** is only necessary if evidence of solid deposits e.g. calcium or similar can be seen around the outlet.

**Disinfection** can be achieved by immersing in an appropriate bactericidal solution, using this method we would strongly recommend removal of the Armitage Bioguard outlet from the spout prior to immersion. For disinfection solution see section 10.11.

**Sterilisation** can be achieved by autoclaving for the desired period. Complete spout can be autoclaved (NB; the seals can withstand this process).

### Self-draining spout

The spout is intended to self-drain after each operation. This means the spout will naturally evacuate the water within the spout cavity. Subsequently, it may appear that the fitting is not shutting off instantly when the handle is moved to the off position. Expect some water to be discharged from the spout for a least a few seconds after shutting off the mixer.

## 10.10 Demounting mixer

In response to the new requirements of HTM 04-01 Addendum, the design of this product permits easy demounting of the mixer from the inlets.

This design permits quick & easy removal of the mixer for cleaning, disinfection and maintenance purposes.

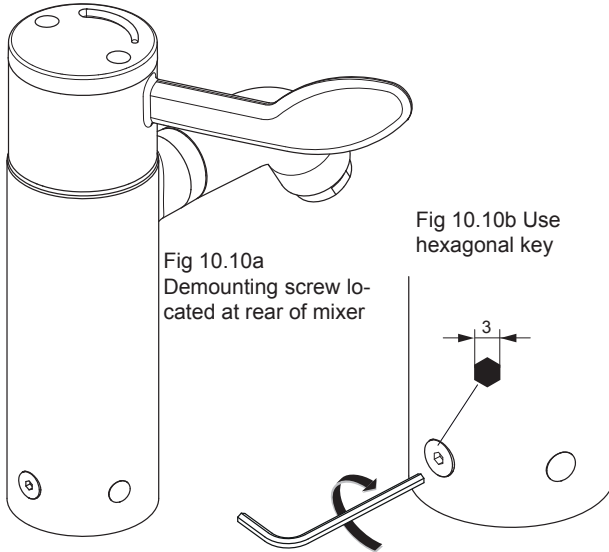
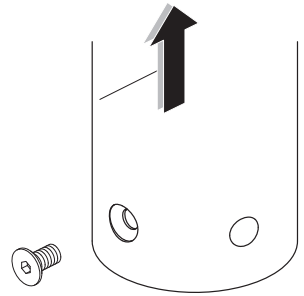

Fig 10.10c remove screw & lift off body



### Method for demounting mixer:

1. Isolate the hot and cold water supplies using the integral isolation valves (see section 10.3). Operate lever to confirm water supplies are closed off.
2. Undo the securing screw located at the rear of the mixer (see fig 10.10a). Use a 3mm hexagon key. (Take care not to lose the screw).
3. Lift the mixer body off from the mixer base, by gently pulling away as shown. Expect a little trapped water to escape. Take care not to damage O-rings.
4. The mixer body can be further dismantled for cleaning protocols. Do not leave the mixer base uncovered for long periods, protect from environmental contamination.
5. To refit the mixer body; reverse this procedure. Tighten the screw at the rear of the mixer securely.

Fig 10.10d Demounting mixer

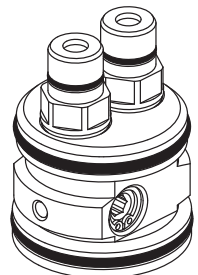
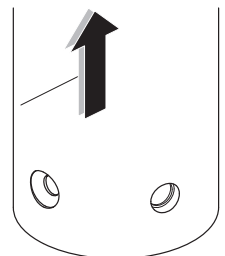

**Take care to avoid damaging the inlet seals. See section 12 & 13 for replacement “demountable base seals”**

Disinfection by full immersion in an appropriate bactericidal solution is recommended for this assembly. Prior to immersion, the mixer body should be clean and dismantled to a level that prevents air locking.

The level of dismantling should be established as a result of practice and will be largely dependent upon the water quality and service life. As a minimum we recommend removal of the lever handle & thermostatic cartridge. Cleaning the cartridge strainer screens is important. All components can be immersed together unassembled.

Disinfected mixers should be promptly replaced or stored using an appropriate method until required. For disinfection solution see section 10.11

### 10.11 Disinfection solution

We recommend parts be immersed in an appropriate bactericidal solution. The frequency of such disinfection actions will be derived from regular sampling carried out under the regime of the Responsible Person (Water). We would not expect to need greater than 6 monthly frequencies, hopefully considerably less.

The need for excessive use of this procedure would be indicative of the need for some root cause analysis as there could be some system or behavioural problems that need addressing.

#### Recommended Disinfection Solutions

For immersion we recommend the use of a 70% Ethanol solution for 10 minutes.

NB: counter intuitively, **greater than recommended concentrations are less effective** not more effective; take care to get the recommended concentration in line with the manufactures recommendation

### 10.12 Integral strainers, CV-FR & safety valves

To ensure trouble free operation of the fitting, the strainer elements should be checked and cleaned in accordance with the commissioning and servicing guide.

To access the strainer elements, close the integral isolation valves (see section 10.3) and demount the mixer (see section 10.10).

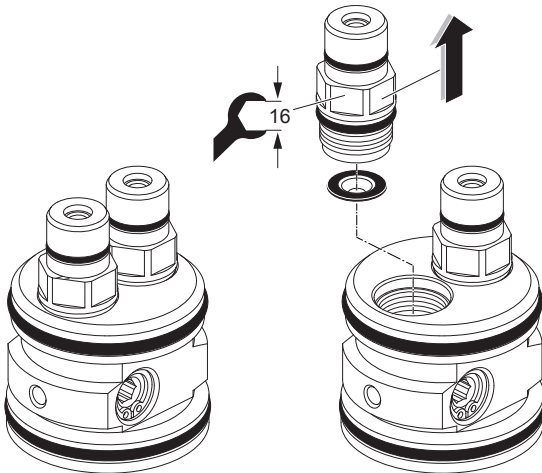

Fig 10.12a Mixer base

Fig 10.12b Removal of check valve housing

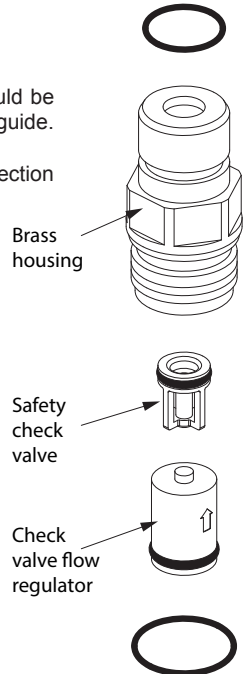

Fig 10.12c Check valve housing exploded

Once the mixer body has been demounted, the brass mixer base will be exposed. See fig 10.12a. To remove the check valve housings:

- Use a 16mm spanner (or small adjustable spanner) to undo the check valve housings.

**Inlet strainers:**

- Look inside the bores & lift out the strainer elements (use long nose pliers if necessary)  
Observe: strainer element is not symmetrical, the underside is convex, see fig 10.12b.
- Wash the strainers in clean water and inspect them for damage, replace if necessary.

**Check valve housing:**

The check valve housing (see fig10.12c) is fitted with two types of check valves:

1. Ø10mm closed body combined check valve flow regulator (CV-FR).
  - a) COLD side (PINK colour)
  - b) HOT side (YELLOW colour)

ENSURE THESE ARE CORRECTLY FITTED (see sections 12 & 13).

The check valves are held in place by O-ring seals, and be simply pull out of the bore of the housing. Observe the flow direction arrow on the check valve body. The main function of the check valves to prevent back syhonage of water to the supply pipes.

NOTE: Wetting the check valve housing with water makes it easier to remove the CV/FR.

2. Ø8mm open body check valve used a safety valve.

These check valves should only be dismantled from the housing if they become faulty. The check valves are difficult to remove & maybe destroyed during the removal process. Spare check valves should be available before attempting this task.

The function of these valves is to shut-off the inlet water supplies in the event that the mixer body is demounted (lifted off the base) without isolating the supplies first. Two prongs inside the mixed body will automatically keep these valves open once the body is correctly reseated on the base. Flow direction of these safety valves is the opposite of the CV-FRs.

IMPORTANT: Although the check valves can be replaced, they must not be removed completely. Do not operate the mixer without all the check valves correctly fitted.

*Armitage  
Shanks*

For more information about our products visit our websites:

[www.armitage-shanks.co.uk](http://www.armitage-shanks.co.uk)

[www.idealspec.co.uk](http://www.idealspec.co.uk)

[www.fastpart-spares.co.uk](http://www.fastpart-spares.co.uk)



# 11 SPARE PARTS A6791NU

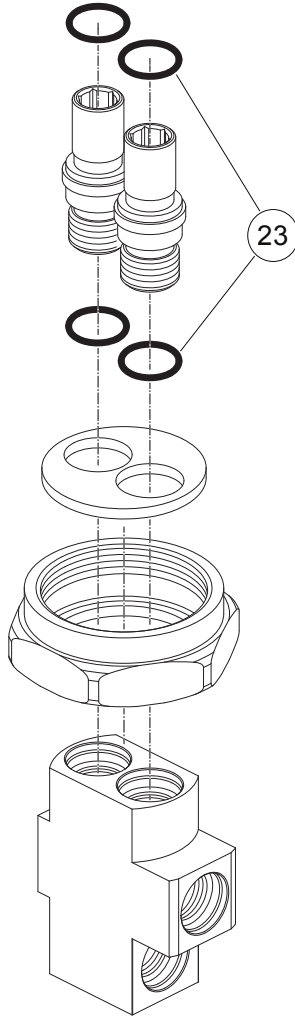

Fig 11 Exploded view of A6791NU

*Armitage  
Shanks*



For more information on spare parts why not visit our spare website:  
**[www.fastpart-spare.co.uk](http://www.fastpart-spare.co.uk)**  
or contact customer care

# 12 SPARE PARTS A6696AA

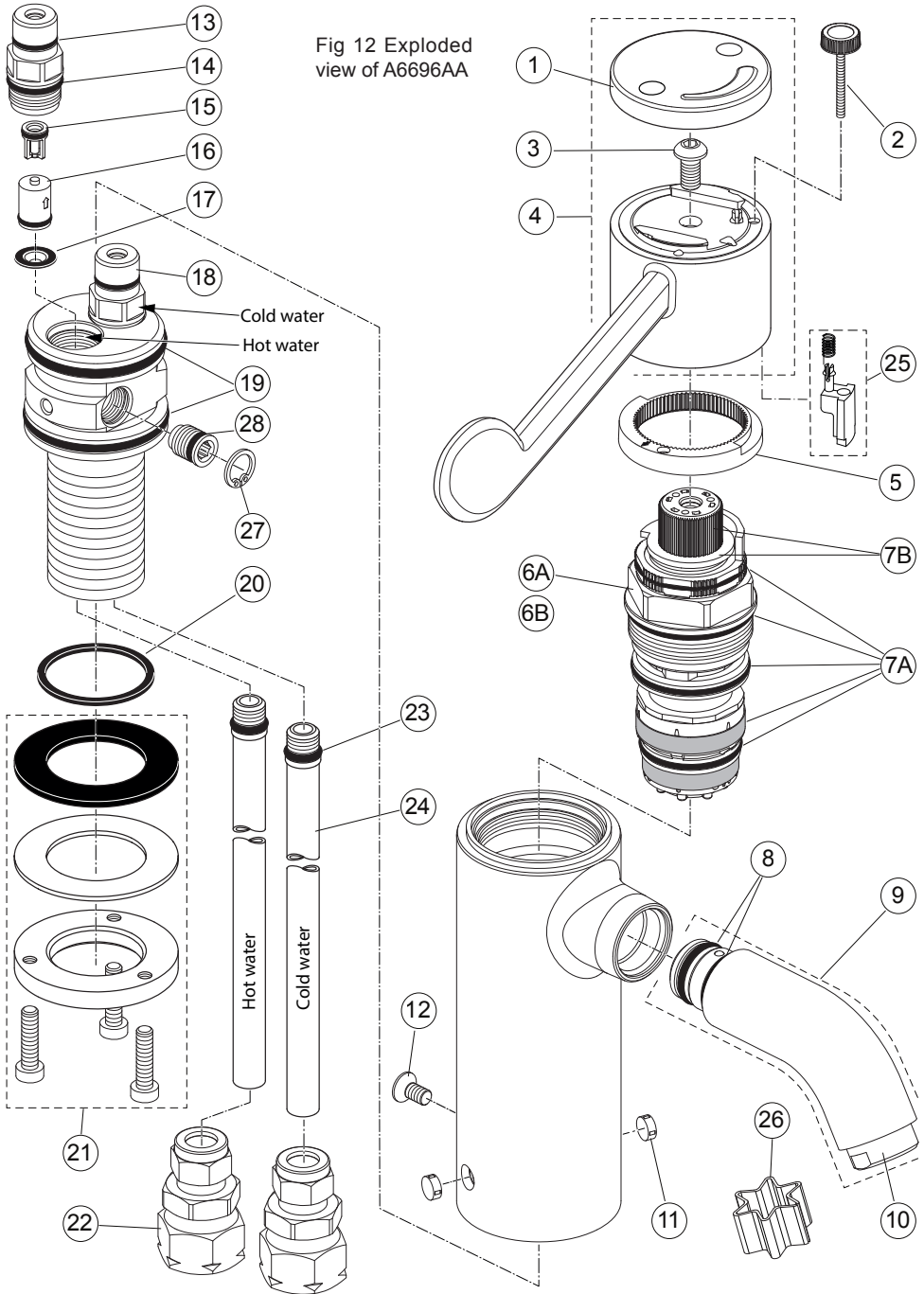

## 13 SPARE PARTS LIST

Ref.	Description	Part No.
1	Cap for handle - Armitage Shanks	A861159AA
2	Tool for thermal override M3x30	A860888NU
3	Handle retaining screw M5x10	A961950NU
4	Lever handle SET, including cap & screw	A861184AA
5	Stop ring (lower ring for temperature adjustment)	A861122NU
6A	Thermostatic cartridge with one stop ring	A861123NU
6B	Thermostatic cartridge –one stop ring - box of 10 pieces	A861289NU
7A	O-ring & strainer SET for thermostatic cartridge	A861166NU
7B	Splined cap & splined locking ring -cartridge	A861310NU
8	O-ring Ø15x2.5 (for removable spout) PAIR	F961003NU
9	Spout removable SET, including O-rings & Bioguard outlet	A861185AA
10	Armitage Bioguard outlet, including O-ring	F960847AA
11	Grommet Ø8.1x3 single	B960583NU
12	Body retaining screw M5x10	A861186NU
13	O-ring for Ø11x1,5 check valve housing	A962218NU
14	O-ring for Ø14x1,78 check valve housing,pair	A962605NU
15	Safety check valve Ø8mm, single	A962099NU
16	Combined CV&FR Ø10mm, cold water (pink)	A861215NU
16b	Combined CV&FR Ø10mm, hot water (yellow)	A861216NU
17	Strainers, pair	A861187NU
18	Inlet connector CV&FR cpl., cold water	A861188NU
18b	Inlet connector CV&FR cpl., hot water	A861218NU
19	O-ring SET for demountable base	A861189NU
20	Sealing ring	F960185NU
21	M30 Clamping kit & seal, set	A861190NU
22	Coupler straight – 10 to 15mm pipe, single	A963289NU
23	O-rings Ø8x1.88, pair	A963306NU
24	Copper inlet pipe M10 with O-rings (single)	B960459NU
25	Disinfection interlock + spring	A861276NU
26	Brass flow straightener (star shape insert - optional)	S961044NU
27	Circlip (Pack contains 4x parts)	A861346NU
28	O-Ring dia 8.1 x 1.6 (single)	A962345NU



For more information on spare parts why not visit our spare website:  
**[www.fastpart-spares.co.uk](http://www.fastpart-spares.co.uk)**  
 or contact customer care

## 14 CLEANING CHROME SURFACES

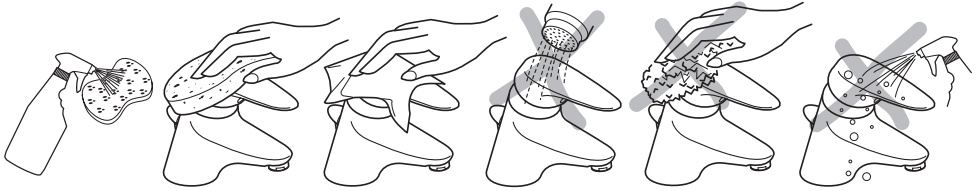

When cleaning chromed products use only a mild detergent, rinse & wipe dry with a soft cloth. Ideally clean after each use to maintain appearance.

Never use abrasive, scouring powders or scrapers. Never use cleaning agents containing alcohol, ammonia, hydrochloric acid, sulphuric acid, nitric acid, phosphoric acid or organic solvents. Use of incorrect cleaning products / methods may result in chrome damage which is not covered by the manufacturer's guarantee.

For more information about our products visit our websites:

[www.armitage-shanks.co.uk](http://www.armitage-shanks.co.uk)

[www.idealspec.co.uk](http://www.idealspec.co.uk)

[www.fastpart-spares.co.uk](http://www.fastpart-spares.co.uk)



**AFTER SALES NON RESIDENTIAL HELPLINE**

**0870 122 8822**

**AFTER SALES NON RESIDENTIAL FAX**

**0870 122 8282**

**E-MAIL**

**[aftersalesnonresidential@idealstandard.com](mailto:aftersalesnonresidential@idealstandard.com)**

Armitage Shanks pursues a policy of continuing improvement in design and performance of its products.

This right is therefore reserved to vary specification without notice.

Armitage Shanks is a division of  
Ideal Standard (UK) Ltd

Ideal Standard International NV  
Corporate Village - Gent Building  
Da Vincilaan 2  
1935 Zaventem  
Belgium

[www.idealstandardinternational.com](http://www.idealstandardinternational.com)

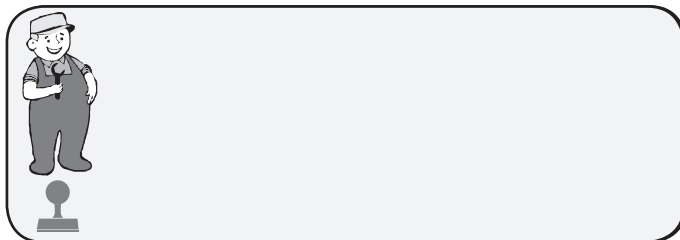

*Armitage  
Shanks*

0519 / A 868 311  
Made in Germany