

*Armitage
Shanks*

**Markwik 21+ Sequential lever
operated thermostatic mixers**

**INSTALLATION
INSTRUCTIONS**



- A6682AA** Markwik 21+ panel mounted mixer (demountable) with removable spout & Armitage Bioguard outlet
- A6735AA** Markwik 21+ panel mounted mixer (demountable) with fixed spout & Armitage Bioguard outlet
- A6734AA** Markwik 21+ deck mounted mixer (demountable) with fixed spout & Armitage Bioguard outlet

IMPORTANT
BEFORE CONNECTION, FLUSH WATER THROUGH PIPEWORK TO REMOVE ALL DEBRIS ETC. WHICH COULD DAMAGE THE VALVE MECHANISM

INSTALLER: After installation please pass this instruction booklet to user

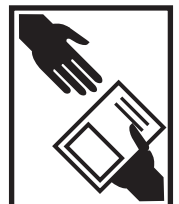

TABLE OF CONTENT

1	TABLE OF CONTENT	2
2	DESCRIPTION	3
3	PRODUCT BOX CONTENTS	3
	3.1 PANEL MOUNTED MIXER DIMENSIONS	4
	3.2 DECK MOUNTED MIXER DIMENSIONS	4
4	WATER SUPPLY CONDITIONS	5
	4.1 WATER REGULATIONS	5
	4.2 INTRODUCTION.....	5
	4.3 SUPPLY PRESSURE REQUIREMENTS.....	5
	4.4 HEALTHCARE ESTABLISHMENTS.....	5
5	INSTALLATION GUIDE.....	6
	5.1 PANEL MOUNTED MIXER	6
	5.2 DECK MOUNTED MIXER	6
	5.3 FLUSHING THE PIPEWORK	7
	5.4 FIXATION OF LEVER HANDLE	7
6	OPERATION.....	8
7	THERMAL CLEANSE	8
8	COMMISSIONING & AUDITS.....	9
	8.1 THE PURPOSE OF COMMISSIONING:.....	9
	8.2 COMMISSIONING PROCESS (SEE DECISION TREE FC1).....	9
	8.3 AUDIT CHECKS ON TMV'S.....	11
	8.4 AUDIT PROCEDURE	12
	8.5 IN-FIELD 'COLD WATER ISOLATION'(CWI) TEST	12
9	SERVICING - TVM3 SCHEME.....	13
	9.1 FREQUENCY OF REGULAR SERVICING.....	13
10	MAINTENANCE	14
	10.1 ADJUSTMENT OF THE MIXED TEMPERATURE	14
	10.2 REMOVAL AND INSPECTION OF CARTRIDGE	15
	10.3 THERMOSTATIC CARTRIDGE AGEING	15
	10.4 ARMITAGE BIOGUARD OUTLET	16
	10.5 OUTLET CLEANING	16
	10.6 SPOUT REMOVAL.....	16
	10.7 DEMOUNTING MIXER.....	18
	10.8 DISINFECTION SOLUTION	20
11	INTEGRAL ISOLATION VALVES	21
	11.1 INLET STRAINERS	22
	11.2 DECK MIXER FLUSHING PROCEDURE	23
	11.3 PANEL MIXER FLUSHING PROCEDURE	24
12	COMBINED CHECK VALVE REGULATORS.....	25
13	MARKWIK 21+ ACCESSORIES.....	26
14	SPARE PARTS PANEL MOUNTED MIXER.....	27
15	SPARE PARTS LIST PANEL MOUNTED MIXER.....	28
16	SPARE PARTS DECK MOUNTED MIXER.....	29
17	SPARE PARTS LIST DECK MOUNTED MIXER	30
18	CLEANING CHROME SURFACES.....	31

2 DESCRIPTION



Markwik 21+ panel & Deck mounted mixer (demountable)

This instruction booklet covers both panel and deck mounted, thermostatically controlled, sequential, lever operated mixers. The mixers are designed to provide water from ambient cold up to a safe maximum temperature for hand wash. They have a built-in thermal shock feature, using the special tool provided, the maximum blend stop can be overridden up to the full hot water supply temperature in the system. (See section 7) The products are fitted with Armitage Bioguard 'anti-microbial copper lined' outlets, reducing the opportunity for bio-film attachment.

The mixers have integral isolating valves and strainers and the thermostatic cartridge also has integral strainers.

Combined check valve regulators are located in the front of each inlet (See section 12)

The hot water side of the body and inlets are thermally insulated to ensure the surfaces are kept at a safe temperature during operation.

The panel mounted mixer is intended to be installed on duct panel walls with a thickness of 13 – 27mm. The deck mounted mixer is intended to be installed on the deck of basins or the worktop housing inset basins with a thickness of 1 – 40mm.

Two Ø30mm holes are required to be cut in the panel or worktop at 200mm centres.

Dry testing & protective caps

These products are delivered to our customers in a dry state. Water testing of these products at the factory has been replaced by air testing, using clean dry filtered air. After testing, both inlets & the outlet are fitted with protective caps to prevent environment contamination entering the product during transit

3 PRODUCTBOXCONTENTS

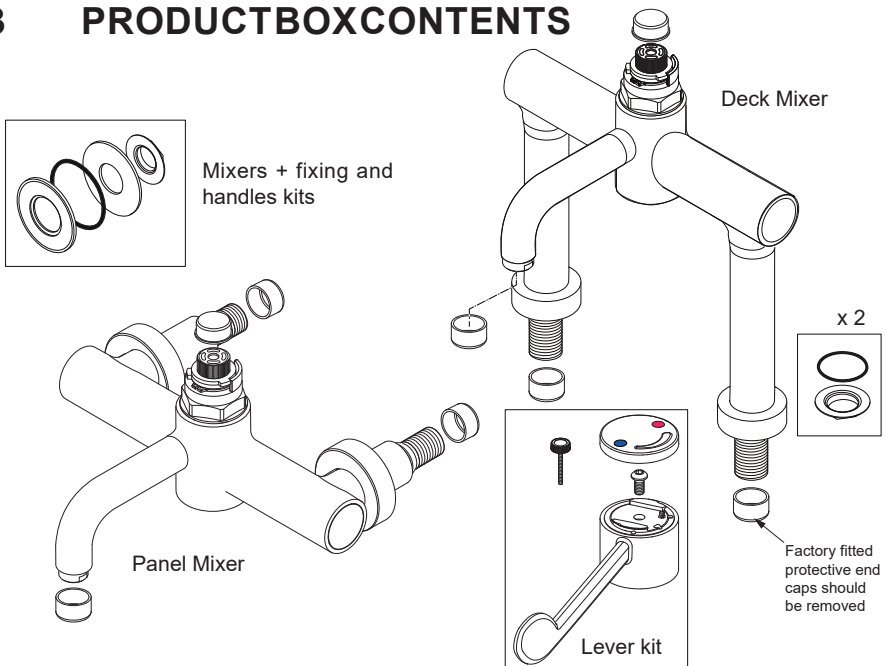

3.1 Panel mounted mixer dimensions

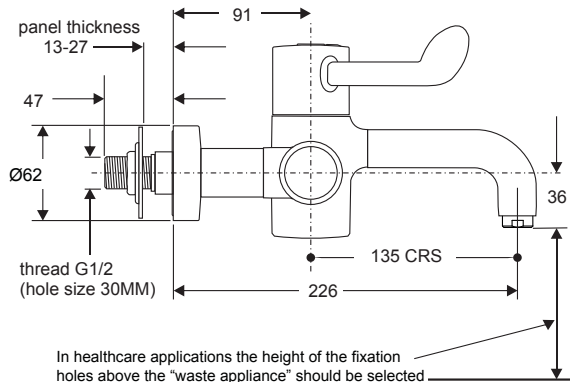
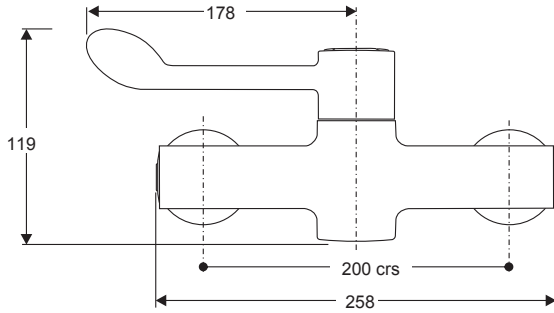

In healthcare applications the height of the fixation holes above the "waste appliance" should be selected to create the recommended "activity space" as defined in HBN 00-10 Part C, typically 150mm – 200mm for a basin and 250mm – 300mm for a surgeon's scrub up trough.

3.2 Deck mounted mixer dimensions

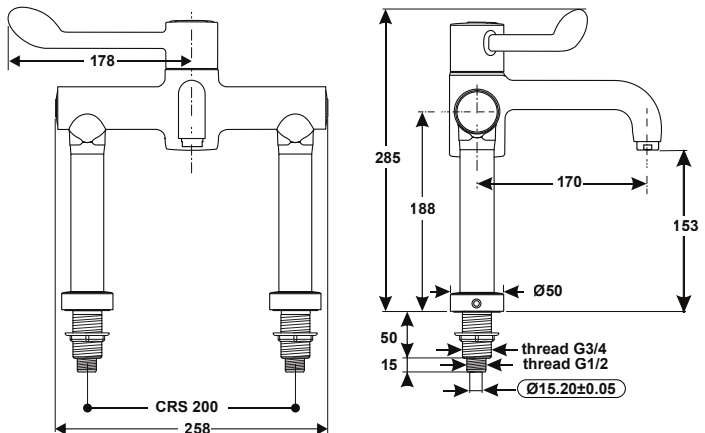

IMPORTANT: Prior to installing mixer, ensure that any existing thermostatic mixing valves (TMVs) that may be fitted are removed

4 WATER SUPPLY CONDITIONS

4.1 Water regulations

The fittings covered by this installation and maintenance instruction should be installed in accordance with the Water Regulations published in 1999*, therefore Armitage Shanks would strongly recommends that these fittings are installed by a professional installer.

*A guide to the Water Supply (Water Fittings) Regulations 1999 and the Water Byelaws 2000, Scotland is published by WRAS (Water Regulations Advisory Scheme)
Unit 13, Willow Road, Pen-y-Fan Industrial Estate, Crumlin, Gwent,
NP11 4EG. ISBN 0-9539708-0-9

4.2 Introduction

This sequential thermostatic lever operated mixer is manufactured to the highest standards and has approval to TMV3 which permits it to be installed in healthcare establishments such as hospitals, nursing homes and residential care homes. When installed in healthcare establishments the supply conditions detailed in Table 1 must be observed and the commissioning and servicing requirements detailed on section 8 & 9 must be followed.

For other installations this is not a requirement.

4.3 Supply Pressure Requirements

This mixer is designed to be installed on all types of plumbing systems.

Hot and cold water supply pressures should be reasonably balanced, however, the mixer will function within specification on unequal pressures up to 5 :1.

The mixer has integral isolating valves which permit servicing of the strainer, combined check valve regulator & thermostatic cartridge. They are also used for Cold water isolation testing.

The minimum pressure for the correct thermal operation is 0.6 bar.

4.4 Healthcare Establishments

In accordance with the NHS model engineering specifications DO8 this valve has approval for the following applications:

High Pressure	HP-	-WE
Low Pressure	LP-	-WE

For this type of application the following supply conditions must apply:

Operating pressure range:	High Pressure	Low Pressure
Maximum static pressure	10 bar	10 bar
Flow pressure hot and cold	1 to 5.0 bar	0.6 to 1.0 bar
Hot supply temperature	55 to 65 °C	55 to 65 °C
Cold supply temperature	5 to 20 °C	5 to 20 °C

Note:

Fittings operating outside these conditions cannot be guaranteed by the scheme to operate as **TMV3**.

Table 1 Supply conditions for healthcare establishments

Effectively this means:

Differential between HOT and COLD inlet temperatures (Δt) must be 35C° min and 60C° max

Differential between HOT inlet temperature and MIXED temperature (Δt) > 14C° preferred

See 8.3 Audit checks on TMV's.

5 INSTALLATIONGUIDE

DO NOT apply heat near this product. Heat generated by soldering could damage plastic parts and seals.

Check that all joints are securely tightened, test for leaks.



5.1 Panel mounted mixer

The panel mounted mixer is designed for panel mounting on a duct wall of maximum thickness 27mm. For thicker panels the rear of the panel will require a counterbore of 62mm or greater

Cut two $\varnothing 30$ mm holes horizontally aligned to 200mm centres. For the panel mounted mixer - See section 3.1 for height positioning of mixer over a "waste appliance".

Loosen the chrome shrouds and insert the fitting as shown above with the wall plates and seals to the front of the wall. Fit the slip washers and do up the backnuts to a torque of 25 Nm. Screw the shrouds onto the wall plates.

Connect the plumbing using G1/2" swivel couplers.

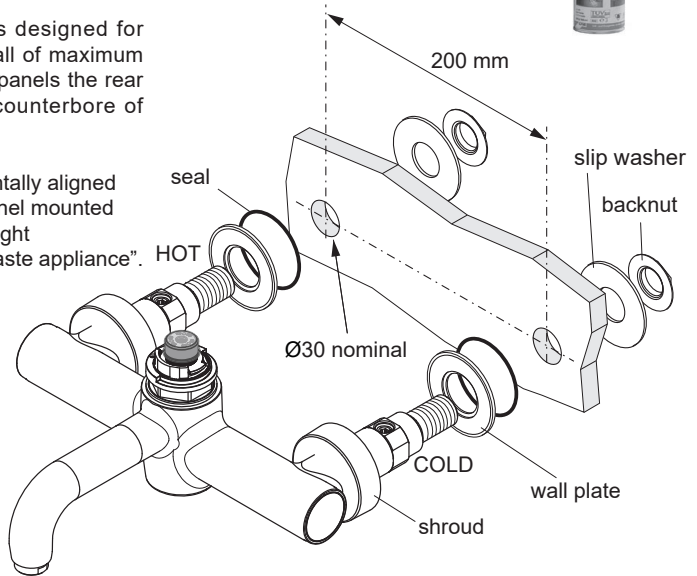

Installation - panel mounting

5.2 Deck mounted mixer

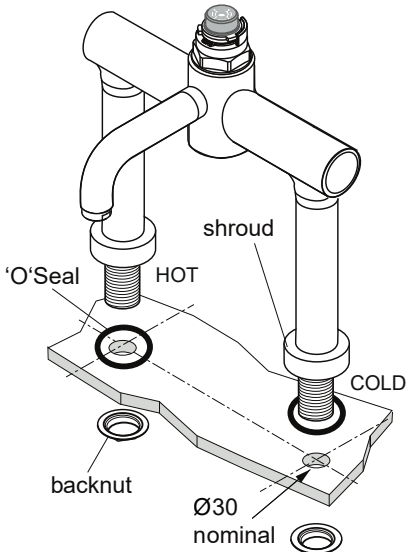

The deck mounted mixer is designed to be deck mounted on a countertop of maximum thickness 40mm

Cut two $\varnothing 30$ mm holes horizontally aligned to 200mm centres.

With the base 'O' Seals fitted, place the inlet tails through the tap holes, fit the backnuts and tighten to 25Nm torque.

Connect the plumbing using $\varnothing 15$ mm compression connection.

Can be fitted onto a basin with holes as described above.

For both mixer types, connect hot water supply to left inlet leg & cold water supply to right inlet leg (as viewed from front).

5.3 Flushing the pipework

IMPORTANT NOTE:

Before operating the products, it is strongly recommended to flush the pipe work to remove any residues or debris remaining after installation. Both panel and deck mixer purging kits are available for this purpose (See 11.2) The purging kits also provide the facility to obtain water supply temperatures at the inlets

5.4 Fixation of lever handle

Two rotational stop rings are fitted to the cartridge.

The inner metal spindle stop ring sets the clockwise off position and the outer polymer ring sets the anticlockwise maximum blend temperature and also provides the thermal override feature.

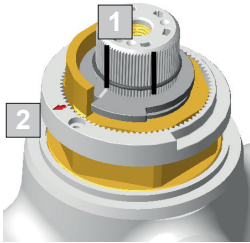

- 1 Fully clockwise off position. Tab of the inner metal stop ring aligns with left black line printed on the cartridge spindle. There is a line on the stop ring to assist alignment
- 2 Position of the outer white polymer temperature stop ring shown at 40°C with the red arrow at the 9 o'clock position facing left.

Removal of these rings is not necessary for handle fixation. However the outer white polymer ring can be rotated when temperature adjustment proves necessary. Clockwise to reduce or anticlockwise to increase the maximum blend temperature.



IMPORTANT! Ensure tab of the inner metal stop ring is firmly against the clockwise rotation stop. If not, rotate the spindle clockwise until it is. The cartridge is now in the off position. If necessary, use the spline drive in the lever handle to rotate the spindle.

Fit the lever handle to the cartridge spindle with cut-out arrow at the 6 o'clock position facing forwards.

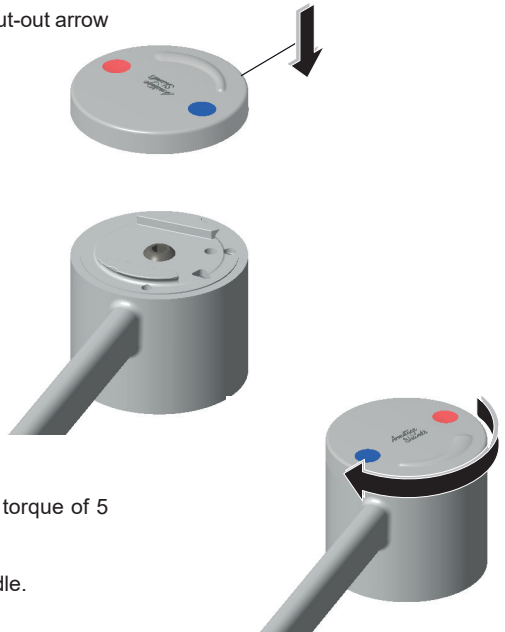
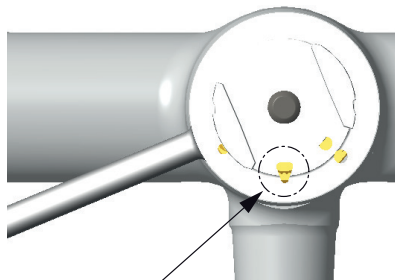

Fit the lever handle screw and tighten fully to a torque of 5 NM using a 4mm hexagon key.

Finally fit the bayonet cover cap to the lever handle.

6 OPERATION

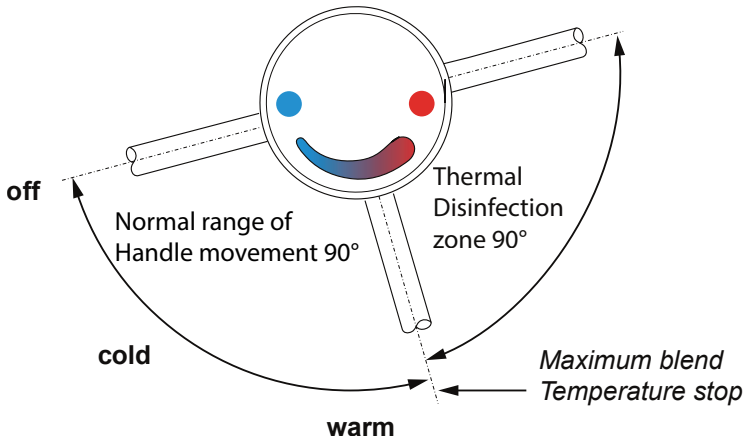

Handle control positions.

Rotate the handle anti-clockwise. The delivered water will progress from cold through warm up to a maximum blend temperature of approximately 41°C

7 THERMAL CLEANSE

Safety Note: Care should be taken when carrying out the following procedure to avoid contact with hot water and hot surfaces.

For Thermal disinfection, this fitting is equipped with a built in thermal cleanse feature. This allows the maximum blend stop to be overridden using the hot water supply temperature in the system.

1. To activate, twist the handle cap anticlockwise and remove
2. Screw the override tool fully into the threaded port on top of the handle
3. Carefully lift the override tool and turn the handle fully anticlockwise

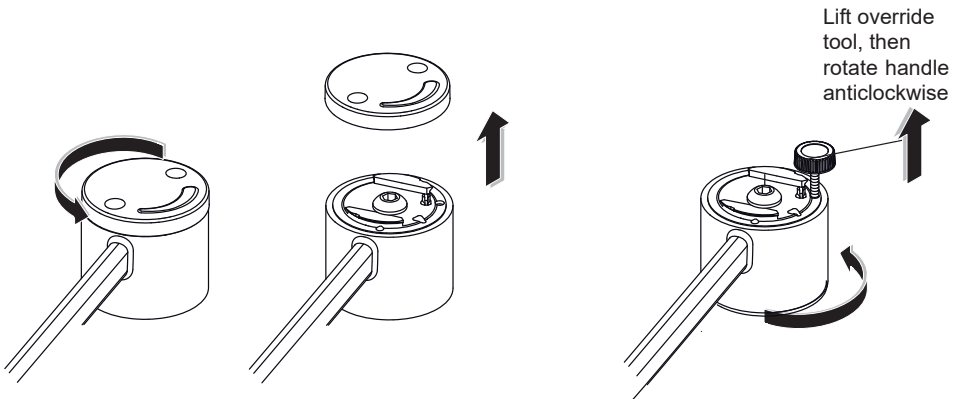

THERMAL CLEANSE CONTINUED

Once the thermal cleanse is complete, simply unscrew and remove the override tool, return the handle to the off position and refit the handle cap. Perform the Cold water isolation (CWI) test (see section 8.5) to ensure the product is working correctly

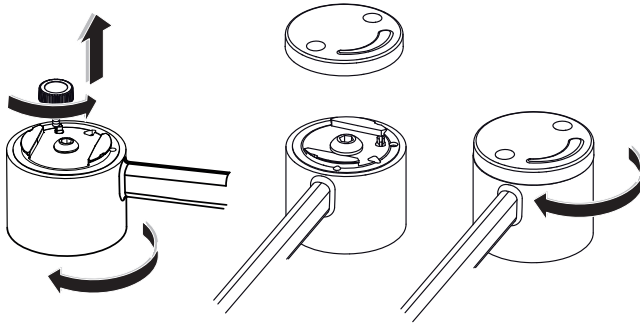

Temperature	Disinfection time
60°C	20 minutes
65°C	10 minutes
70°C	5 minutes

8 COMMISSIONING & AUDITS

The following procedure should be conducted after installation to ensure the product is functioning correctly.

8.1 The Purpose of Commissioning:

- To confirm the correct designation of product versus application.
- To confirm the correct supply water conditions for the product / installation.
- To adjust the mixed temperature if necessary to suit the water supply conditions of the installation.
- To check the product is performing properly.
- To start an audit log and record appropriate data.

These products are factory set at 40°C ± 1°C with supplies of circa; 3 bar balanced pressure and temperatures of 15°C cold & 65°C hot (i.e. an inlet Δt of 50C° & hot / mix Δt of 24C°) For supply requirements, see 4 Water Supply Conditions.

8.2 Commissioning Process (see decision tree FC1)

- Establish that the supply conditions are within the requirements outlined above. If not investigate.
- When conditions are acceptable record them, together with hot and cold temperatures. Establish Δt.

Check the outlet mix temperature is within 41°C ± 2°C, if not (probably due to Δt > 5C° difference to factory setting) adjust appropriately. (see section 10.1)

- If mixed temperature is correct undertake an 'in field' cold water isolation (CWI) test: (see section 8.5)
 - Pass - restore supply and record mixed temperature,
 - Fail - See 8.5 in-field 'Cold Water Isolation' test.

8.2 cont. Commissioning process (decision tree FC1)

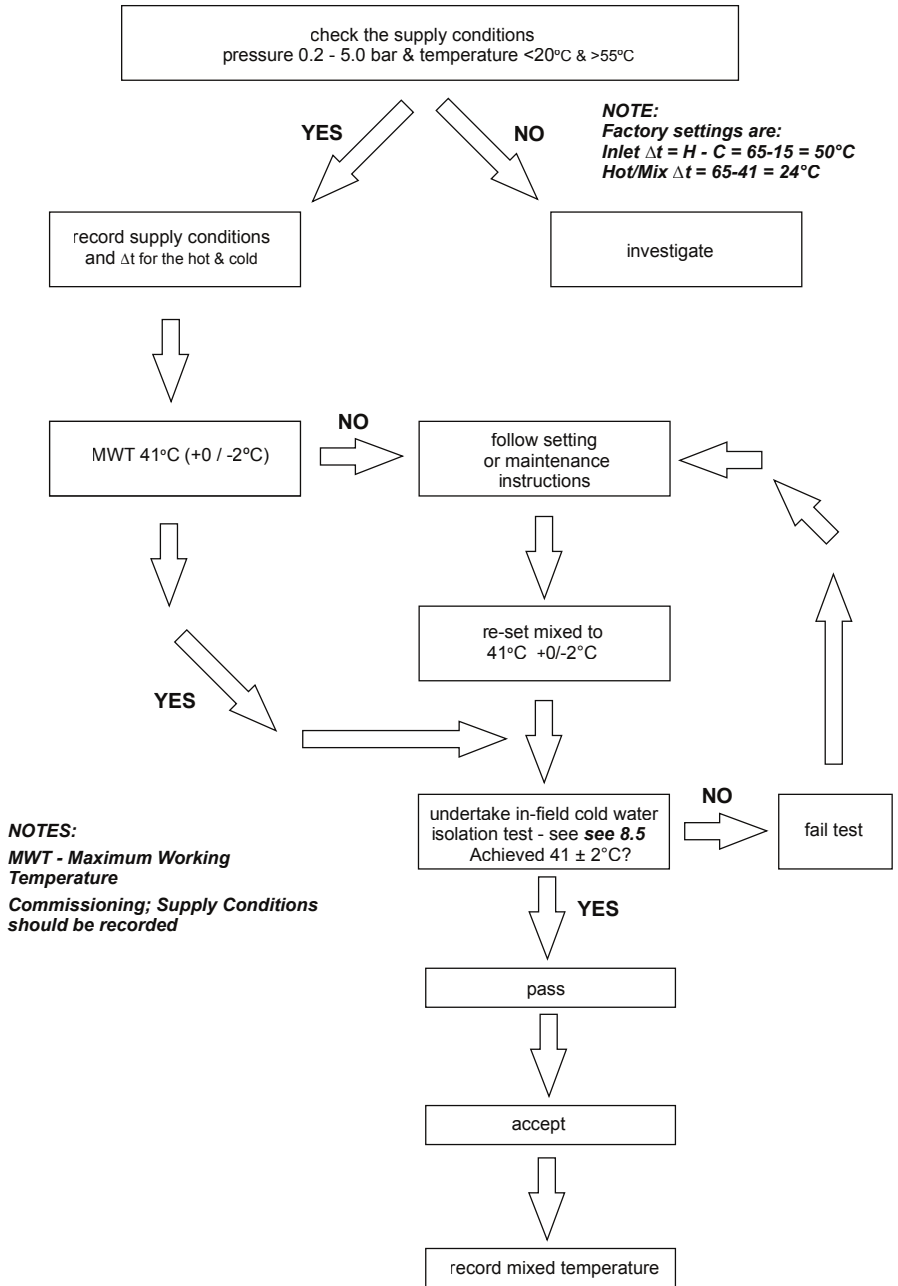

8.3 Audit Checks on TMV's

The purpose of a performance audit of a product is:

- ♦ To check the product continues to perform properly.
- ♦ To flag the need for the product to be adjusted due to supply condition changes or mechanism ageing.
- ♦ To ultimately identify the need for product maintenance.

Note - Additionally these audits facilitate regular verification of the supply conditions in accordance with HTM 04 requirements. (See decision tree FC3)

Audit of Supplies To Fittings (FC3)

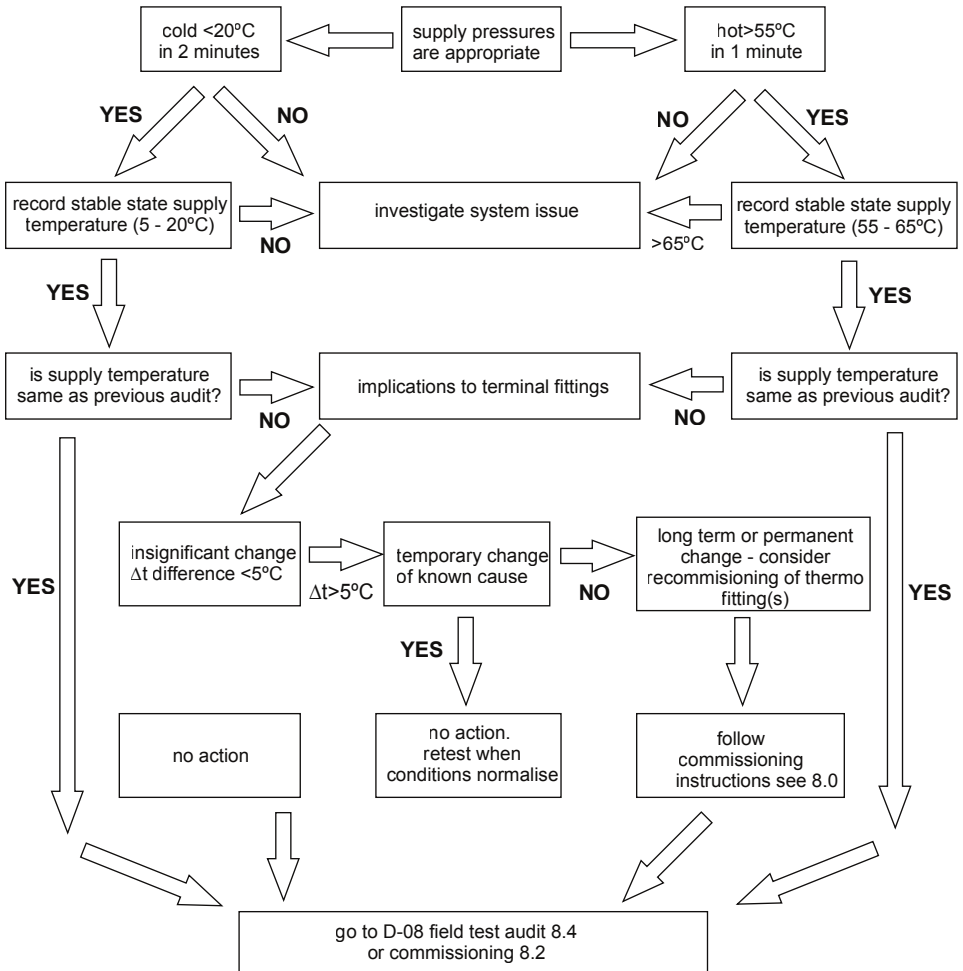

8.4 Audit procedure (see decision tree FC2)

- Verify the water supplies conditions are similar to when the product was commissioned i.e. inlet Δt as previous + / - $5C^{\circ}$

Note: If inlet Δt change is $> 5C^{\circ}$ consider the cause of the change, if it is seen as a long term or permanent change, re-commission the product. If however, it is only a temporary change, retest when normal conditions resume.

- If inlet Δt differs from the commissioning Δt by $< 5C^{\circ}$ carry out field 'cold water isolation' (CWI) test as D-08: 2009. **(see 8.5 in field Cold Water Isolation test failure.)**
- Pass - restore the cold supply and move on to check the mix temperature.

Note: If the product fails CWI test, refer to 8.5 and then re-commission the valve.

- Mixed Temperature is as commissioned $\pm 2C^{\circ}$, Accept and record the temperature.

Note: If mixed Deviation $> \pm 2C^{\circ}$ (1st instance) reset mix as instructions and redo the test from start. See 9.1 Adjustment of the mix temperature.

- 2nd & subsequent instances follow maintenance instructions.

8.5 In-field 'Cold Water Isolation' (CWI) test.

Note: To gain access to the cold water isolating valves see section 11.

Using a 5mm Allen Key, the isolation screw can be rotated fully clockwise to isolate the cold water supply .

Before commencing the CWI test, ensure:

- The water supply conditions are met either:
 - For commissioning a new product **(see table 1, section 4).**
 - Or the inlet Δt is within $\pm 5^{\circ}C$ to when the product was commissioned **(see section 8.4)**

NOTE It is important that the hot temperature is greater than $55^{\circ}C$

- Mixed water outlet temperature is correct (see Table2, section 9)

Fitting Field Test Audit (FC2)

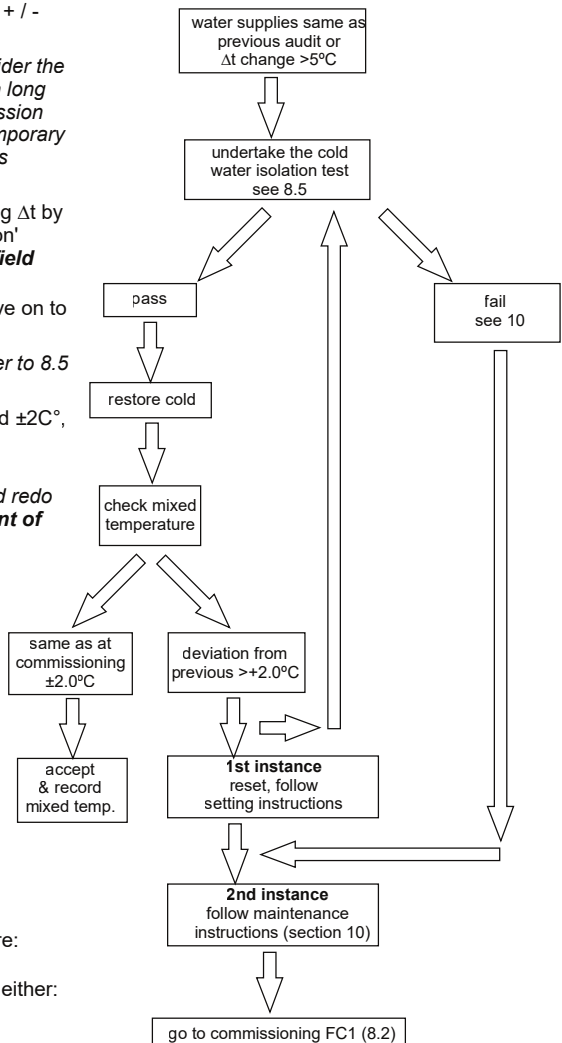

To perform a CWI test, operate the product by rotating the lever fully to the right.

Then conduct the following procedure:

1. Record the steady state temperature of both hot and cold water supplies. Note the Δt .
2. Record the temperature of the mixed water at the outlet.
3. Isolate the cold water supply (by rotating the isolating screw fully clockwise) & monitor the flow of water from the outlet.

If the flow ceases, CWI test passed:

1. Restore the cold water supply by rotating the isolator screw 90° anti clockwise.
2. Slide the shroud back & screw onto the wall plate. **See Section 11 for Deck fitting**
3. Re-check the temperature of the stabilised mixed water at the outlet to ensure it is still correct.

Accept & record mixed temperature.

If there is an ongoing flow of water from the mixed water outlet, then 5 seconds after CWI collect the discharging water into a measuring vessel for 60 seconds. To pass the CWI test the volume of collected water should be less than 120ml.

If the product fails CWI test, see FC2 (**see section 8**) . Follow product maintenance (**see section 10**) and servicing (**see section 9**) instructions.

9 SERVICING-TVM3SCHEME

The need for servicing is normally identified as a result of the regular performance auditing.

Application	Maximum mixed water temperature during normal operation	Permitted maximum stabilised temperature recorded during site testing – excluding transient spikes
Washbasin	41°C	43°C

Table 2 A guide to maximum temperature sets

9.1 FREQUENCY OF REGULAR SERVICING

The purpose of servicing regularly is to monitor any changes in performance due to changes in either the system or the product. This may highlight the need to adjust either the supply system or the product. These products should be audited 6 to 8 weeks and again 12 to 15 weeks after commissioning. The results are to be compared against original commissioning settings.

If the product passes the audit test three consecutive times (demonstrating good stability of system & product) then a 12 monthly servicing cycle may be adopted.

Otherwise, servicing checks should be carried out more frequently (e.g. every 4 months).

Follow the recommended auditing and maintenance procedures detailed in sections 8 & 10.

During servicing, note the following:

1. Repeat the procedure of recording and checking supply temperatures. (The same type of measuring equipment should be used)
2. If the temperature has changed significantly from the previously recorded values, the following should be checked:
 - a. All in-line or integral valve filters are clear of obstruction.
 - b. All in-line or integral check valves are clean and working properly to prevent backflow.
 - c. All isolating valves (integral to service valve) are fully open.
 - d. The thermostat is free of debris
3. When satisfied with the mixed outlet temperatures re-record the temperatures.

10 MAINTENANCE

10.1 Adjustment of the mixed temperature

Note: Cartridge is factory pre-set at 40° +/- 1°C @3Bar
With differing supply conditions may require adjustment in order to maintain set temperature



1. Twist the handle cap anticlockwise and lift it off
2. Unscrew the retaining screw using a 4mm Allen key and lift off the handle
3. To adjust the max blend temperature lift, rotate and refit the maximum blend temperature stop ring.
 - To increase the temperature, rotate the ring anticlockwise
 - To reduce the temperature rotate the ring clockwise
4. Upon successful completion of the temperature adjustment, conduct the Cold Water Isolation (CWI) test (See 8.5) to ensure the product is working correctly.
5. Refit the Handle and cap and record the mixed temperature

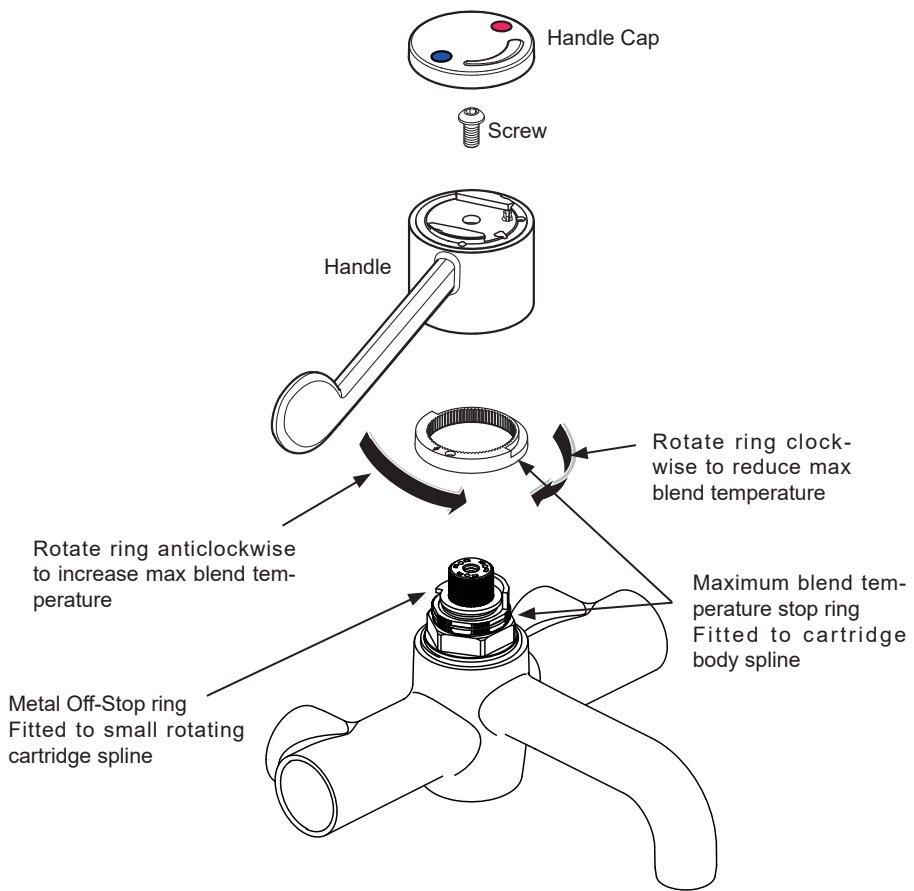

10.2 Removal and inspection of cartridge

After checking that supply conditions are within the specified parameters (**See section 4.3, Table 1**), if the mixer malfunctions or should the test results fail to fall within the specified limits, consider replacing the cartridge with a new one.

Isolate the mixer with the integral isolation screws **See section 11**

Remove the handle as described in 10.1. Unscrew the cartridge from the body with a 36mm A/F deep socket. Inspect cartridge for damage.

Replace cartridge if necessary and re-assemble into body.

The replacement cartridge should be tightened to a torque of 15Nm

Replace lever handle (**See section 5.3**) and reinstate the supplies

After fitting the new cartridge start the test procedure from the section on commissioning

- Redo the Cold Water Isolation (CWI) test (**See section 8.5**)
- Once satisfied with the CWI test, re check and if necessary, adjust the maximum mix temperature, (**See section 10.1**)
- Record the mix temperature

The Thermostatic cartridge has built-in strainers, these should be inspected and if necessary washed with clean water or replaced (**See section 15 & 16**)

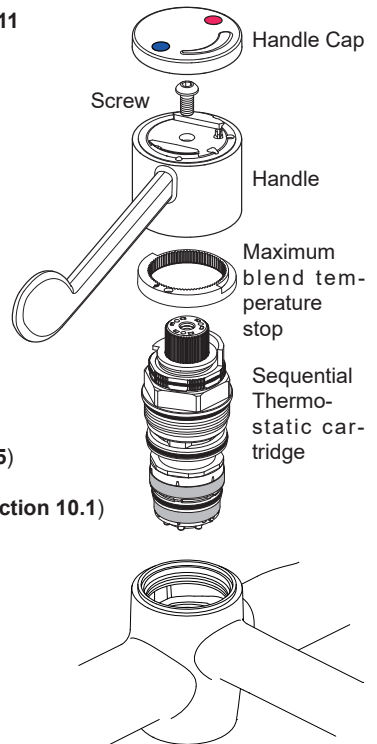

10.3 Thermostatic Cartridge Ageing

Following many years of normal service you may notice the following:

1. The need to carry out more frequent adjustment of mixed temperature.
2. The thermostatic element may not pass the CWI test.

These issues could be due to the ageing of the thermostat which loses some expansion capability over time.

These are the principle objectives of testing, as they serve to indicate to maintenance staff the declining performance capability of the thermostatic cartridge.

For this reason the audit testing flow chart highlights that 2nd Instance CWI test failure or 2nd instance mixed deviation even with stable 'as commissioned' supply conditions and correct inlet supply Δ t's, is potentially the first indication of the need to replace the cartridge.

10.4 Armitage Bioguard Outlet

Traditional “flow straightener” type outlets have recently been identified by extensive research as an area most likely to harbour bacteria. This product uses an Armitage Bioguard outlet which replaces this traditional flow straightener with a fully open copper-lined waterway. This greatly reduces the risk of bacteria build-up whilst the copper lining has natural anti-microbial properties.

Outlet is suitable for autoclaving.

In the interests of infection control and health hygiene, the Armitage Bioguard Outlet is a supplement to, not a substitute for, standard infection control practices. Continue to follow all current protocols, including those practices related to cleaning and disinfection of surfaces. Refer to HTM04-01 for more details.

Patent pending for Armitage Bioguard antibacterial outlet, application No: 10 2012 107 243.4

OUTLET Strainer: The Armitage Bioguard outlet can be removed (as described below) & replaced with a universal filter adaptor, see section 15. The adaptor will accept most types which are externally threaded M24x1.

10.5 Outlet cleaning

On a regular basis the outlet should be inspected and cleaned.

To unscrew and remove the outlet, use an adjustable spanner on the flats (20mm). To refit, hand tighten and then use the spanner until the outlet has bottomed in the bore. Take care not to over tighten.

In areas where lime scale build-up is prevalent this should be avoided by regular cleaning. If it should build up, it will have to be removed. An inhibited proprietary scale solvent can be used such a kettle descaling solvent but it is important to follow the manufacturer’s guidelines. After descaling it is important to rinse the parts thoroughly in clean water. Clean carefully and do not use abrasive materials or scrapers

Note: Lime scale deposits should be removed prior to using any disinfection treatments.

10.6 Spout removal

The A6682AA Markwik 21+ panel mounted mixer is fitted with a quick easily removable spout to assist with cleaning, disinfection by immersion or sterilisation by autoclaving.

Procedure assumes availability of a replacement spout. For both practical functional reasons along with environmental contamination reasons, the mixer should not be left without a spout in place

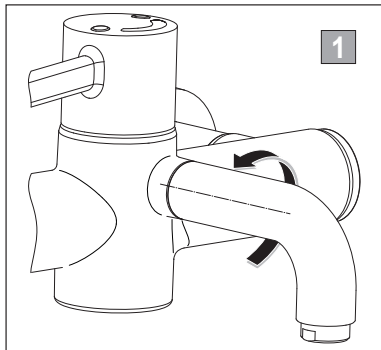

1. Ensure the handle is in the off position.
To remove the spout: gently rotate the end of the spout anticlockwise by 90°.

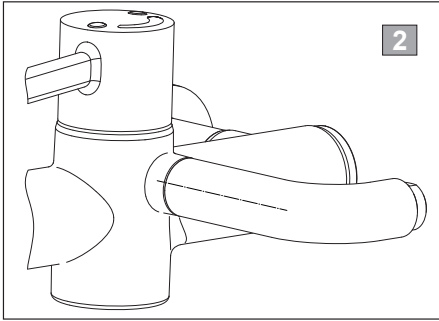

2. The spout should now be in the horizontal position as shown.

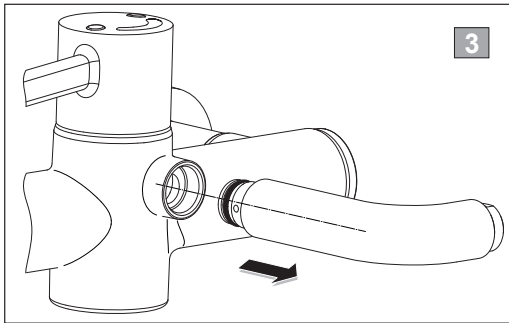

3. Gently pull the spout away from the body as shown.

Quarantine this spout for cleaning protocols.

Ensure replacement spout complies with cleaning protocols.

To refit a spout, reverse this procedure.



IMPORTANT:
Do not leave the mixer outlet open without a spout fitted.

Additional spouts are available so during cleaning protocols an alternative spout can be fitted while the original is removed. This insures continuity of use of the mixer.
For additional spout part numbers, **See section 13.**

Cleaning / disinfecting / sterilising the removed spout.

Physical **cleaning** is only necessary if evidence of solid deposits e.g. calcium or similar can be seen around the outlet.

Disinfection can be achieved by immersing in an appropriate bactericidal solution, using this method we would strongly recommend removal of the Armitage Bioguard outlet from the spout prior to immersion.

For disinfection solution **See section 10.8.**

Sterilisation can be achieved by autoclaving for the desired period. Complete spout can be autoclaved (NB; the seals can withstand this process).

10.7 Demounting mixer

In response to the new requirements of HTM 04-01 Addendum, the designs of these mixers have been enhanced to permit easy demounting of the mixer from the inlets.

This updated design permits quick & easy removal of the mixer for cleaning, disinfection and maintenance purposes

Prior to commencing this procedure, you should have available either a replacement mixer (without inlets) or a pair of protective cover caps. **See section 13.**

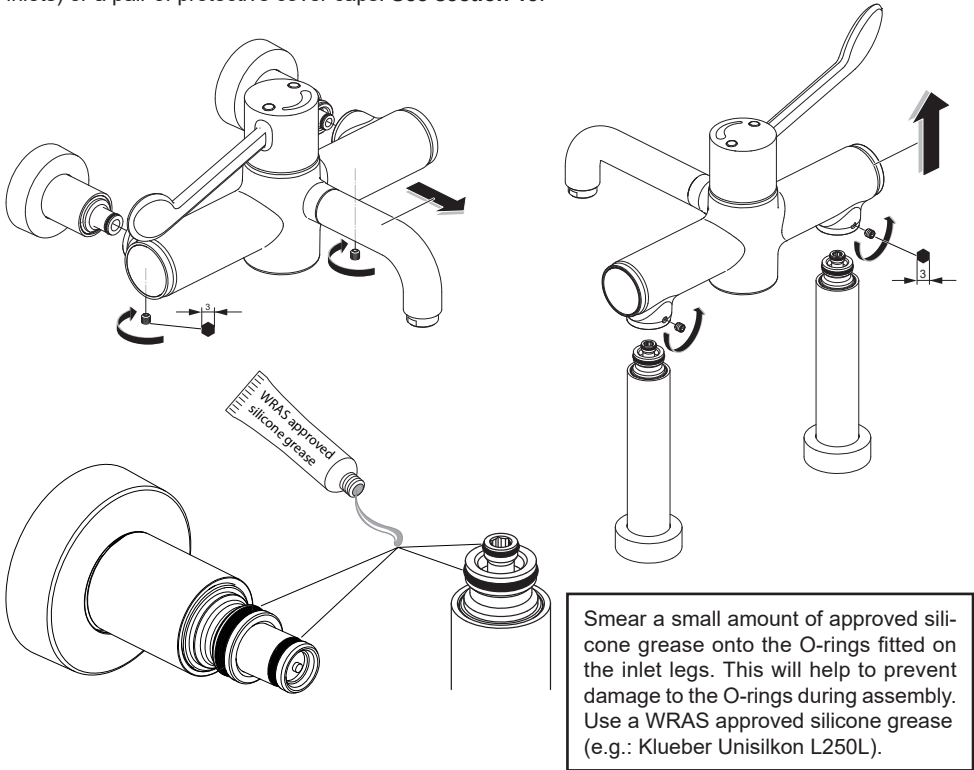

Method for demounting mixers:

1. Isolate the hot and cold water supplies using the integral isolation valves. (See section 11) Operate lever to confirm water supplies are closed off.
2. Undo the 2 grub screws securing the mixer using a 3mm hexagon key. (Take care not to lose the screws).
3. Remove the mixer from the inlets, by gently pulling away as shown. Expect some trapped water to escape.
4. To ease remounting of the mixer lightly smear the O-rings of the inlet legs with WRAS approved grease (e.g.: Klueber Unisilikon L250L). Wipe off any excess.
5. During cleaning protocols: Fit cover caps to protect & seal the inlets (**See section 13**).
6. To refit the mixer; reverse this procedure. Tighten screws securely.



Take care to avoid damaging the inlet seals. Damage to these seals would compromise the insulate feature & affect the mixer's thermostatic performance. See section 13 for spare "demountable seal kit".

Demounting mixers continued

Inlet O-ring damage

If the front O-ring seals (as shown below) fitted on the inlet legs become damaged, then leaking water will cause pressure build-up inside the fitting & eventually force out an end cap.

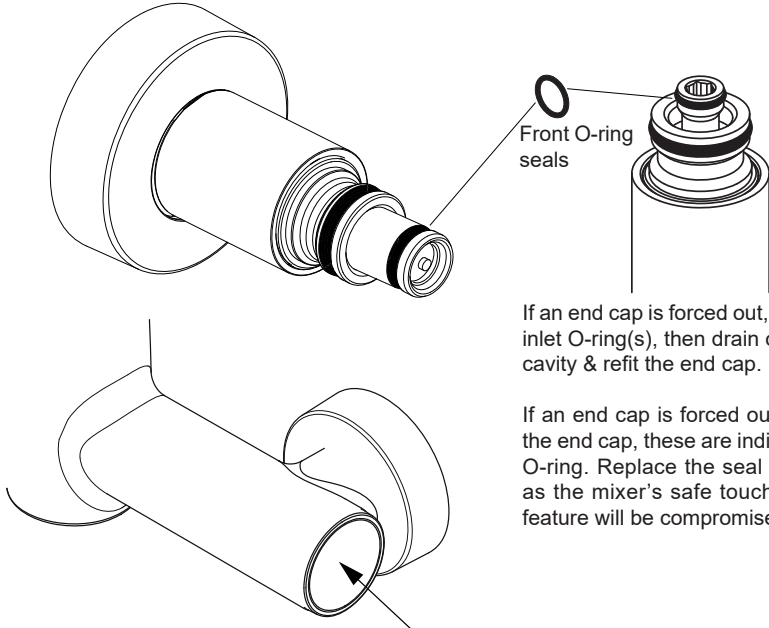

If an end cap is forced out, replace the damaged inlet O-ring(s), then drain off any water from the cavity & refit the end cap.

If an end cap is forced out, or water drips from the end cap, these are indications of a damaged O-ring. Replace the seal as soon as possible, as the mixer's safe touch (thermal insulation) feature will be compromised.



IMPORTANT NOTE: END CAPS. The chromed end caps should not be removed. There are no serviceable parts within this cavity.

Inlet legs – removal

If one or both inlet legs are removed from the panel for maintenance or repair, then it is **important** to note the following:

ALIGNMENT

Prior to installation, both inlet legs must be securely fixed to the mixer body. Fit the complete assembly to the panel, then secure with the back-nut kit. Back nut torque 25Nm.

Note: **Do not** separate inlet legs & install them individually onto the panel, as alignment to mixer body will be lost. In this case, mixer body will not correctly locate onto the inlet legs & may damage the O-rings during installation.

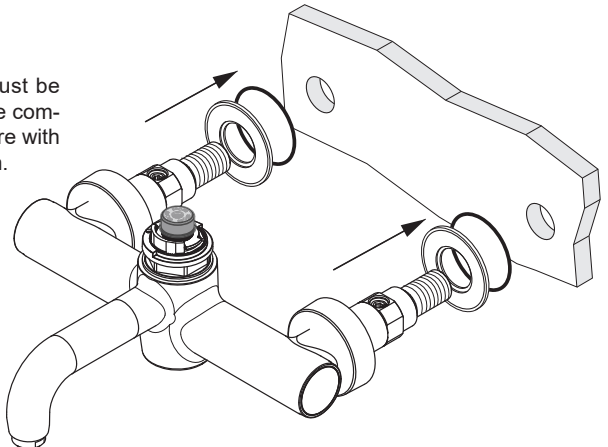

Demounting mixers continued

Disinfection by full immersion in an appropriate bactericidal solution is recommended for this assembly. Prior to immersion, the fitting should be clean and dismantled to a level that prevents air locking.

The level of dismantling should be established as a result of practice and will be largely dependent upon the water quality and service life. As a minimum we recommend removal of the lever handle & thermostatic cartridge. Cleaning the cartridge strainer screens is important. All components can be immersed together unassembled.

Disinfected mixers should be promptly replaced or stored using an appropriate method until required. For disinfection solution **See section 10.8**

Protective cover caps

For both practical functional reasons along with environmental contamination reasons, the inlets should not be left open

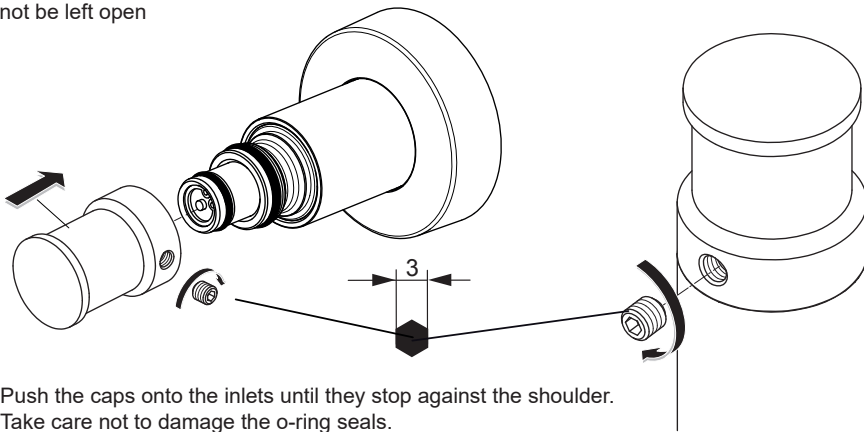

Push the caps onto the inlets until they stop against the shoulder.
Take care not to damage the o-ring seals.
Secure the cap with grub screw as shown using a 3mm Hexagonal key. Leave the hot & cold supplies isolated.
Cover caps should be disinfected / sterilised when necessary.



IMPORTANT:
Do not leave the mixer inlets open without a body or cover caps fitted.

10.8 Disinfection solution

We recommend parts be immersed in an appropriate bactericidal solution

The frequency of such disinfection actions will be derived from regular sampling carried out under the regime of the Responsible Person (Water). We would not expect to need greater than 6 monthly frequencies, hopefully considerably less.

The need for excessive use of this procedure would be indicative of the need for some root cause analysis as there could be some system or behavioural problems that need addressing.

Recommended Disinfection Solutions

For immersion we recommend the use of a 70% Ethanol solution for 10 minutes.

NB: counter intuitively, **greater than recommended concentrations are less effective** not more effective; take care to get the recommended concentration in line with the manufactures recommendation.

Avoid using disinfection solutions that contain ammonia. Note: ammonia can lead to stress corrosion cracking of the brass components inside the fitting.

11 INTEGRAL ISOLATION VALVES

The integral isolation valves facilitate a number of activities:

- Servicing the thermostatic cartridge
- Cleaning or replacing the strainers
- Audit Cold Water Isolation (CWI) test
- Demounting the mixer from its inlets

To isolate the mixers, proceed as follows:

1. On the panel mounted mixers, unscrew the wall shrouds and slide forward, on the deck mounted mixer remove the small index buttons at the base of the shrouds.
2. Isolate both inlets by screwing isolation valves down fully using a 5mm Allen key in the clockwise direction.
3. Reverse procedure to restore the water supplies and refit the shrouds / index buttons.

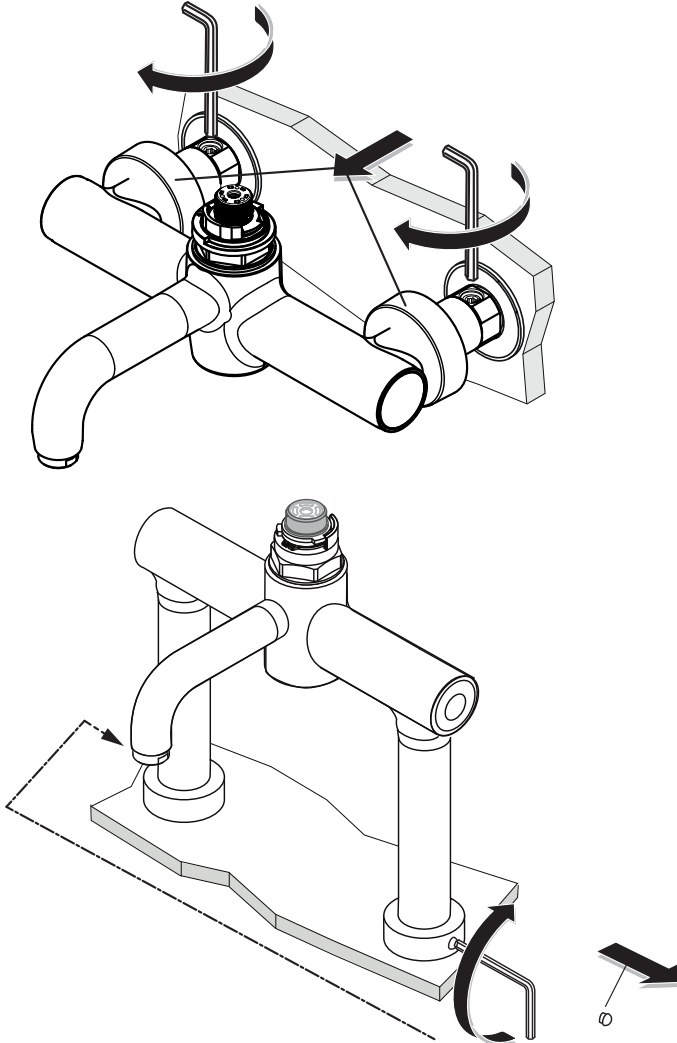

11.1 Inlet Strainers

To ensure trouble free operation of the fitting, the strainer elements should be checked and cleaned in accordance with the commissioning and servicing guide.

To access the strainer element, close the isolation valves and demount the mixer (**see section 10.7**)

Deck mounted fitting

1. Lift one piece chrome shroud off the inlet

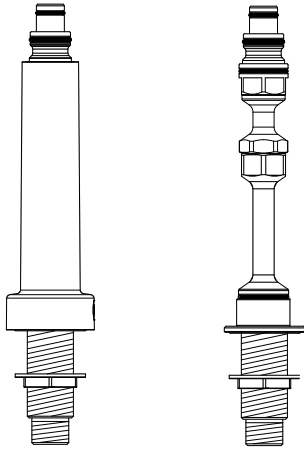
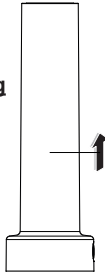

2. To access the strainer, using two 25mm A/F spanners retain the bottom inlet and unscrew the top inlet assembly

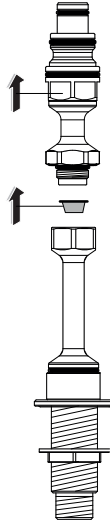

3. The strainer element should be washed with clean water and refitted

4. Re-assemble the inlet

5. Re-fit the chrome shroud taking care to line up the small access hole in the base of the shroud with the isolation screw on the inlet.

Panel mounted fitting

1. Unscrew and remove the Chrome Panel Shrouds and pull the Chrome Sleeves forward off the inlet seals.
2. Isolate both inlets by screwing the isolation valves down fully using a 5mm hexagon key in the clockwise direction. (Operate lever to confirm water supplies are closed off).
3. Undo the 2 grub screws securing the mixer using a 3mm hexagon key. (Take care not to lose the screws).
4. Remove the mixer from the inlets, by gently pulling forwards. Expect some trapped water to escape
5. Unscrew and remove the strainers from the underside of the Inlets using a 5mm hexagon key.
6. The strainers should be inspected and washed with clean water and can be Autoclaved or replaced as necessary
7. Before re-assembling the strainers we recommend flushing the inlets with our purging and water sampling kit - A6899NU (not included)
8. When refitting the strainers, **DO NOT OVER TIGHTEN**, observe torque setting shown above.

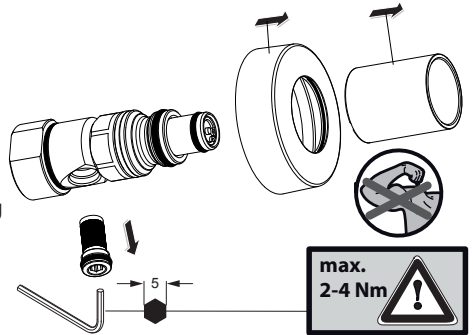

11.2 Deck mixer Flushing procedure

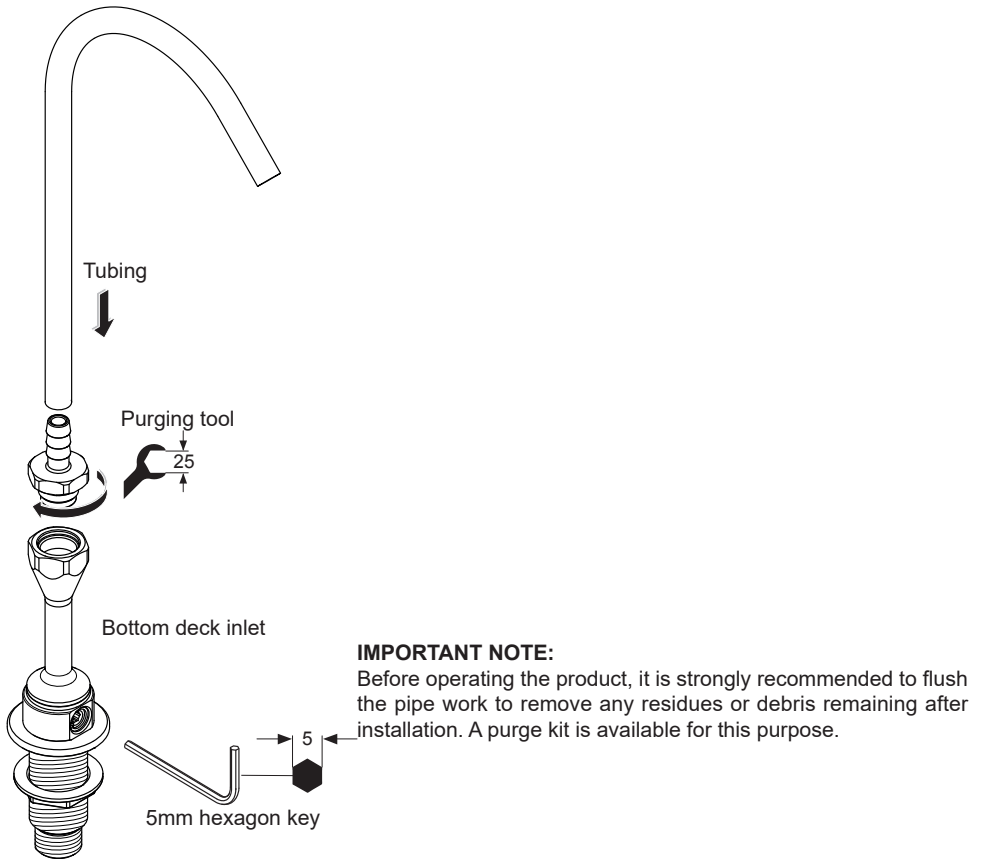

The purging kit also provides the facility to obtain water supply temperatures at the inlets.

Safety Note: Care should be taken when carrying out the following procedure to avoid contact with hot water and hot surfaces. We recommend the use of protective hand wear.

The following procedure should be used to flush out the pipework:

1. Remove the strainer from the inlets as detailed in section 11.1 to gain access to the purging port.
2. Screw the purging tool fully into the inlet port.
3. Attach tubing to the purging tool and direct into the basin.
4. Open the isolating valve and allow water to discharge into the basin until the water flows clean.
5. Repeat on the both sides of the mixer so that both the hot and cold supplies are flushed.

Once the system has been flushed, remove the purging kits and refit the strainers with the sealing washer facing upwards and the strainer mesh facing downwards.

Re-assemble the top inlets and Chrome Inlet Sleeves and secure the body back onto the inlets with a 3mm hexagon key

11.3 Panel mixer Flushing procedure

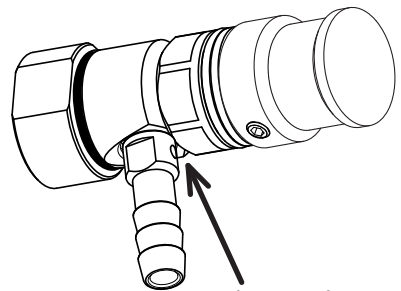
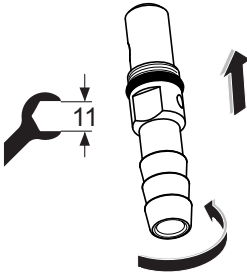
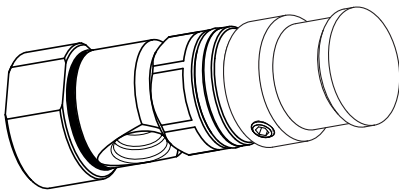
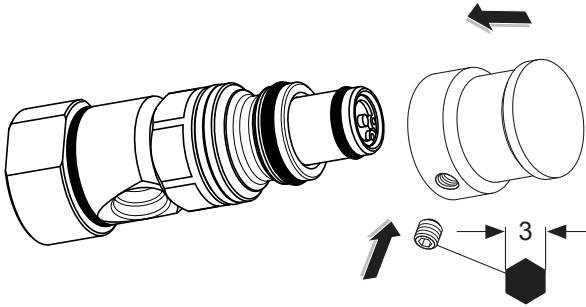

Important!

Small indent on the purging kit must be aligned towards the front of the inlet.

Safety Note: Care should be taken when carrying out the following procedure to avoid contact with hot water and hot surfaces. We recommend the use of protective hand wear.

The following procedure should be used to flush out the pipework:

1. Remove the strainer from the inlet with a 5mm hexagon key to gain access to the purging port.
2. Screw the purging kit into the inlet port fully and then unscrew until the small indent on the purging kit towards the front of the inlet as shown.
3. Open the isolating valve and allow water to discharge into a vessel until the water flows clean. Suitable tubing can be push fitted onto the purging kits if required.
4. Repeat on the both sides of the mixer so that the hot and cold supplies are both flushed.

Once the system has been flushed, remove the purging kits and refit the strainers using a 5mm Allen key. **DO NOT OVER TIGHTEN**, observe torque setting shown in section 11.1.

Re-assemble the Chrome Inlet Sleeves and Panel Shrouds and secure the body back onto the inlets with a 3mm hexagon key.

12 COMBINED CHECK VALVE REGULATORS

To prevent back siphonage of water to the supply pipes, check valve regulators (CV/FR's) are fitted inside the inlet tails.

These CV/FR's can be replaced, but **MUST NOT BE REMOVED**.

Replacement Instructions

Close the isolation valves

Demount the mixer (**See section 10.7**)

First remove the Ø12mm circlip using suitable internal circlip pliers.

The CV/FR can now be removed using long nose pliers; however there is a high probability of damage during removal.

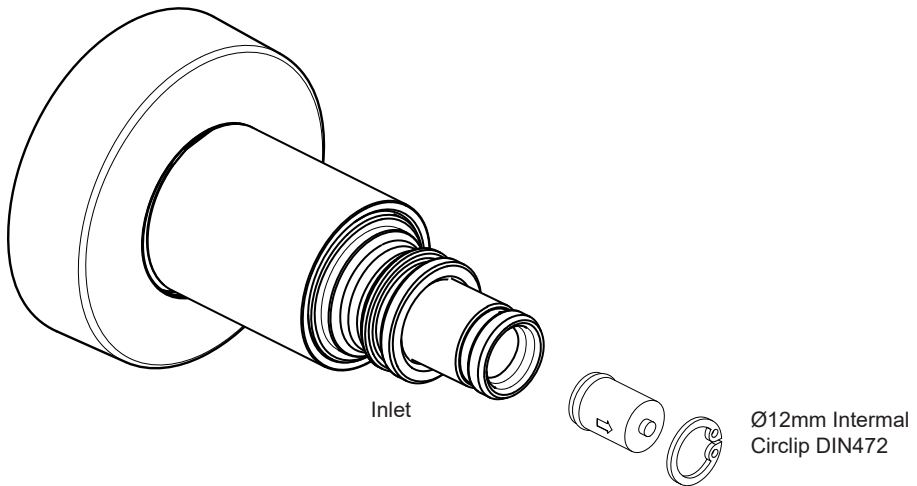

IMPORTANT:

The CV/FR's can be replaced but must not be removed

The pink CV/FR must be fitted to the cold water inlet (Right side of the mixer when viewed from the front)

The yellow CV/FR must be fitted to the hot water inlet (Left side of the mixer when viewed from the front)

13 MARKWIK 21+ ACCESSORIES

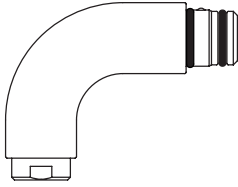

A6252AA
 Panel mount spout complete.
 Short version with 100mm reach.
 Fitted with Armitage Bioguard outlet
 & o-rings at the mixer coupling end.
See section 10.6



A6250AA
 Panel mount spout complete.
 With normal 135mm reach.
 Fitted with Armitage Bioguard outlet
 & o-rings at the mixer coupling end.
See section 10.6

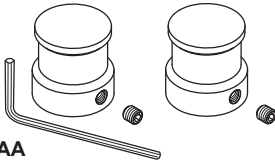

A6255AA
 Cover caps kit.
 To protect & seal the inlets legs when
 a mixer has been demounted & removed.
See section 10.7



A6256AA
 Universal filter adaptor.
 Replaces the Armitage Bioguard outlet
 to permit attachment of an outlet filter.
 Threaded M24x1 (internal).

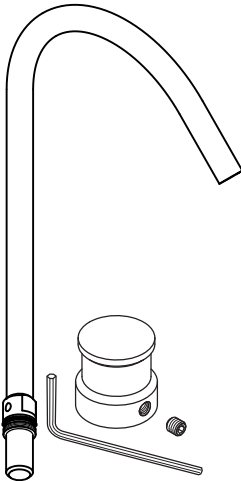

A6899NU
 Panel Flushing set
See section 11.3

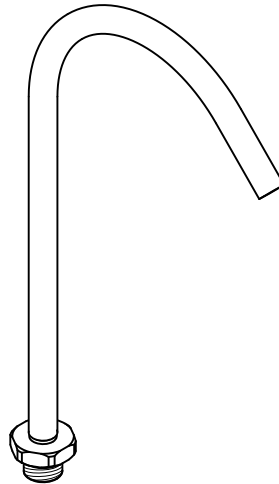

A6898NU
 Deck Flushing set
See section 11.2

14 SPARE PARTS PANEL MOUNTED MIXER

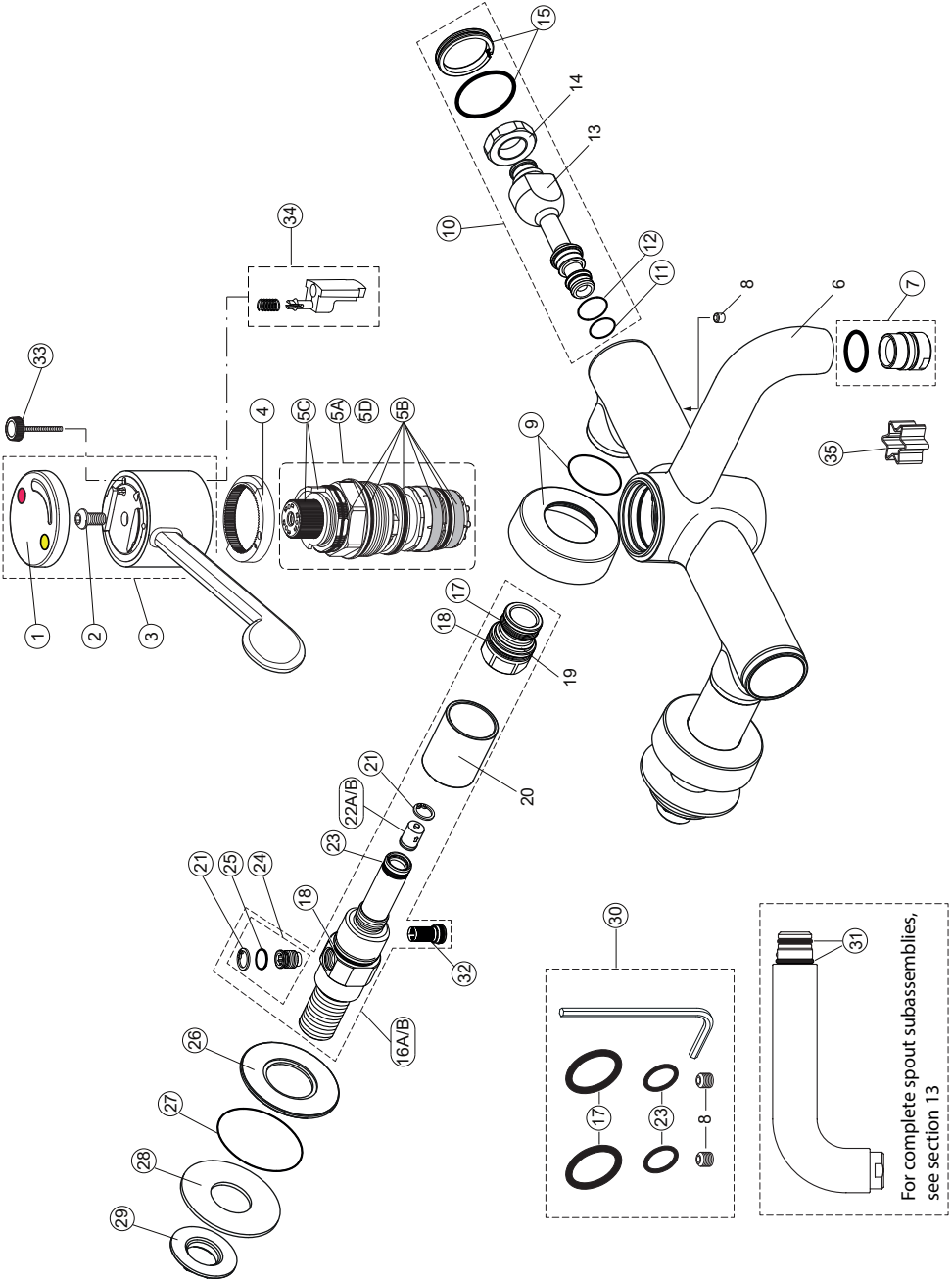

15 SPARE PARTS LIST PANEL MOUNTED MIXER

Ref.	Description	Part No.
1	Cap	A861159AA
2	Handle screw	A961950NU
3	Handle SET	A861158AA
4	Stopring	A861122NU
5A	Sequential, thermostatic cartridge	A861123NU
5B	O - ring set thermostatic cartridge + strainer set	A861166NU
5C	Splined cap & splined locking ring -cartridge	A861310NU
5D	Thermostatic cartridge –one stop ring - box of 10 pieces	A861289NU
6	Body	--
7	Outlet	F960847AA
8	Screw (Available in 30 set)	--
9	Escutcheon + O-ring	A962346AA
10	Side sleeve cpl.	A861160NU
11	O - ring Ø 11 x 2	A960942NU
12	O - ring Ø 13 x 2	A861101NU
13	Sleeve	--
14	Threaded nut M18x1,5	--
15	Cap w. o - ring Ø 30 x 2	A861124NU
16A	Inlet Set, cold water	A861347AA
16B	Inlet Set, hot water	A861348AA
17	O-ring 17 x 2.5	A963143NU
18	O - ring Ø 24 x 2	A961809NU
19	Inlet insulator	--
20	Inlet Sleeve	--
21	Circlip (Pack contains 4x parts)	A861346NU
22A	Combined CV&FR Ø10mm, cold water (pink) right side	A861215NU
22B	Combined CV&FR Ø10mm, hot water (yellow) left side	A861216NU
23	O - ring Ø 12,42 x 1,78	A961332NU
24	Isolation plug cpl. (2 sets)	A861329NU
25	O-ring dia 8.1 x 1.6 (single) - (available within item 16)	A962345NU
26	Wall plate	E960633NU
27	O-ring Ø51 x 2.4	E960632NU
28	SLIP WASHER Ø60 X Ø25 X 2	E960631NU
29	Backnut	E960112NU
30	Demountable seal kit with grub screws, o-rings & hex key	A861162NU
31	O-ring Ø15 x 2.5	F961003NU
32	Strainer	A861172NU
33	Override tool	A860888NU
34	Disinfection interlock + spring	A861276NU
35	Brass flow straightener (star shape insert - optional)	S961044NU

16 SPARE PARTS DECK MOUNTED MIXER

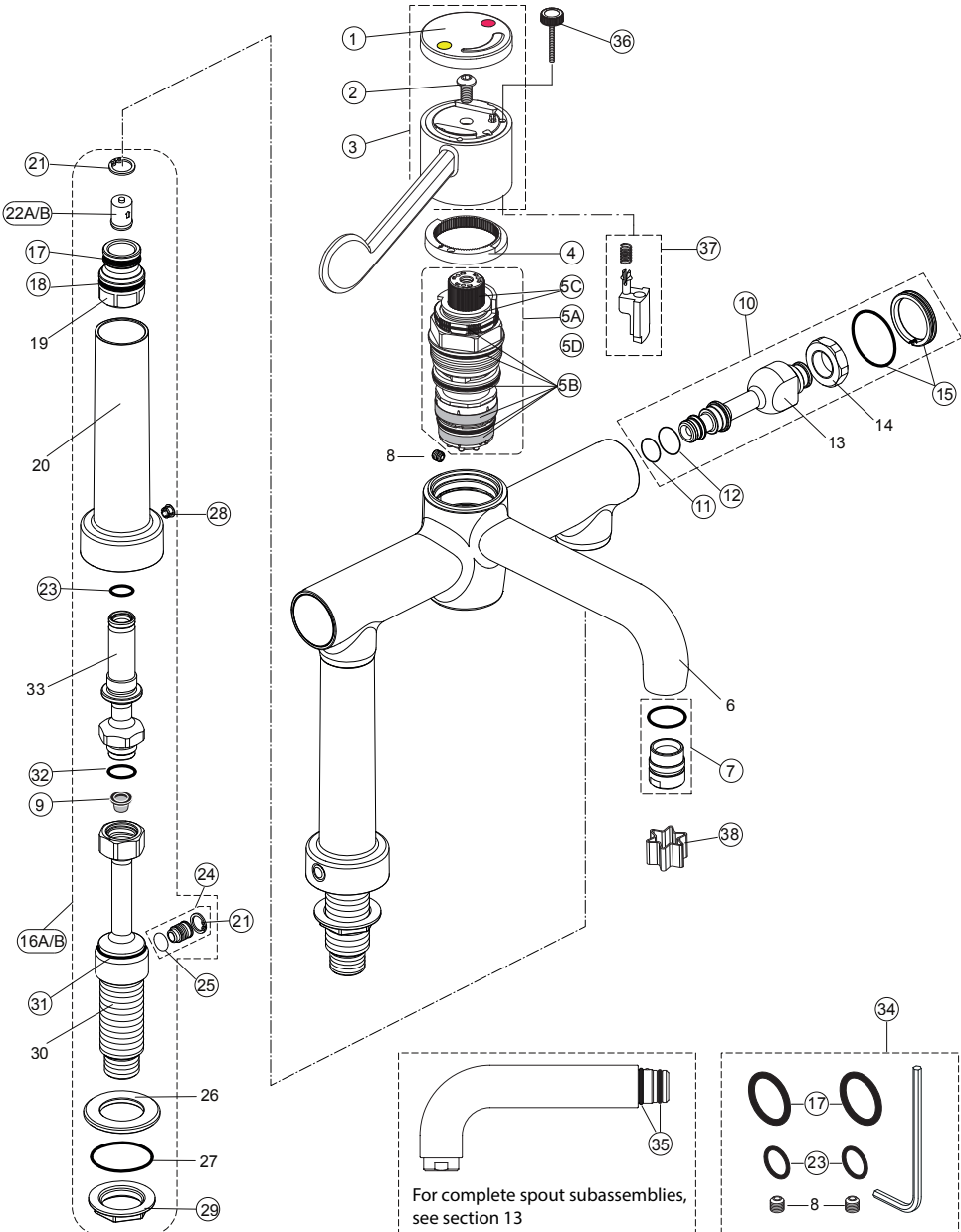

17 SPAREPARTSLISTDECKMOUNTEDMIXER

Ref.	Description	Part No.
1	Cap	A861159AA
2	Handle screw	A961950NU
3	Handle SET	A861158AA
4	Stopring	A861122AA
5A	Sequential, thermostatic cartridge	A861123NU
5B	O - ring set thermostatic cartridge + strainer set	A861166NU
5C	Splined cap & splined locking ring -cartridge	A861310NU
5D	Thermostatic cartridge –one stop ring - box of 10 pieces	A861289NU
6	Body	--
7	Outlet	F960847AA
8	Screw (Available in 30 set)	--
9	Strainer	F961032NU
10	Side sleeve cpl.	A861160NU
11	O - ring Ø 11 x 2	A960942NU
12	O - ring Ø 13 x 2	A861101NU
13	Sleeve	--
14	Threaded nut M18x1,5	--
15	Cap w. o - ring Ø 30 x 2	A861124NU
16A	Inlet Set, cold water	A861349AA
16B	Inlet Set, hot water	A861161AA
17	O - ring 17 x 2.5	A963143NU
18	O - ring Ø 24 x 2	A961809NU
19	Inlet insulator	--
20	Escutcheon	--
21	Circlip (Pack contains 4x parts)	A861346NU
22A	Combined CV&FR Ø10mm, cold water (pink) right side	A861215NU
22B	Combined CV&FR Ø10mm, hot water (yellow) left side	A861216NU
23	O - ring Ø 12,42 x 1,78	A961332NU
24	Isolation plug cpl. (2 sets)	A861329NU
25	O - ring dia 8.1 x 1.6	A962345NU
26	Deck Plate	--
27	O-ring Ø51 x 2.4	E960632NU
28	Indice	A960396AA
29	Backnut	E960111NU
30	Bottom deck inlet	E960631NU
31	O - ring Ø24 x 2	A961809NU
32	O - ring Ø15,6 x 1,78	A963916
33	Top deck inlet	--
34	Demountable seal kit with grub screws, o-rings & hex hey	A861162NU
35	O - ring Ø15 x 2.5	F961003NU
36	Override tool	A860888NU
37	Disinfection interlock + spring	A861276NU
38	Brass flow straightener (star shape insert - optional)	S961044NU

OTHER PRODUCTS WITHIN THE MARKWIK 21+ RANGE



A6737AA

Panel mount thermostatic mixer, Sensor operated – timed flow (Demountable) with fixed spout & Armitage Bioguard outlet

A6684AA

Panel mount thermostatic mixer, Sensor operated – timed flow (Demountable) with removable spout & Armitage Bioguard outlet.



A6696AA

Markwik 21+ thermostatic basin mixer with copper inlet pipes. Includes demountable body, removable spout & Bioguard outlet



A6791NU

Markwik 21+ Back to wall connecting kit for closed wash basins

18 CLEANING CHROME SURFACES

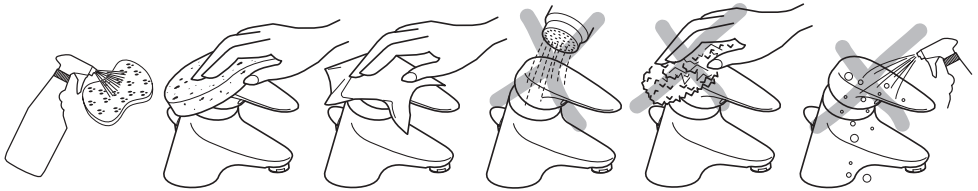

When cleaning chromed products use only a mild detergent, rinse & wipe dry with a soft cloth. Ideally clean after each use to maintain appearance.

Never use abrasive, scouring powders or scrapers. Never use cleaning agents containing alcohol, ammonia, hydrochloric acid, sulphuric acid, nitric acid, phosphoric acid or organic solvents. Use of incorrect cleaning products / methods may result in chrome damage which is not covered by the manufacturer's guarantee.

For more information on accessories contact our customer care.

For more information about our products & spares
visit our websites:

www.idealstandard.co.uk



AFTER SALES NON RESIDENTIAL HELPLINE
0870 122 8822

AFTER SALES NON RESIDENTIAL FAX
0870 122 8282

E-MAIL
aftersalesnonresidential@idealstandard.com

Armitage Shanks pursues a policy of continuing improvement in design and performance of its products.

This right is therefore reserved to vary specification without notice.

Armitage Shanks is a division of
Ideal Standard (UK) Ltd

Ideal Standard International NV
Corporate Village - Gent Building
Da Vincilaan 2
1935 Zaventem
Belgium

www.idealstandardinternational.com

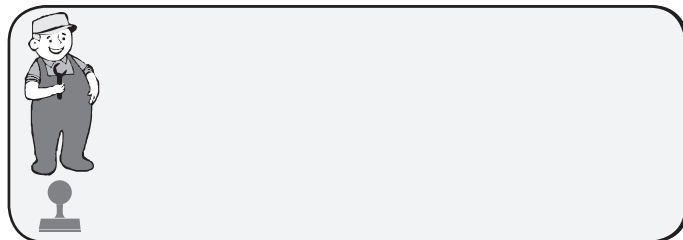

*Armitage
Shanks*

0421 / A 868 250
Made in Germany