

*Armitage  
Shanks*

**Sensorflow 21 basin mixers  
A4124AA, A4176AA, A4177AA**

**INSTALLATION  
INSTRUCTIONS**

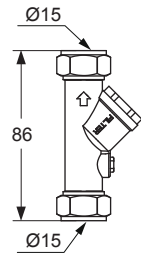
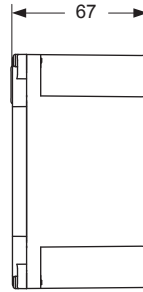
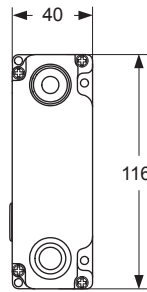
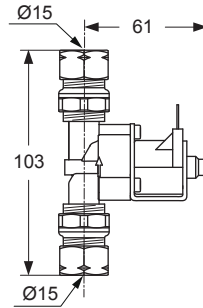
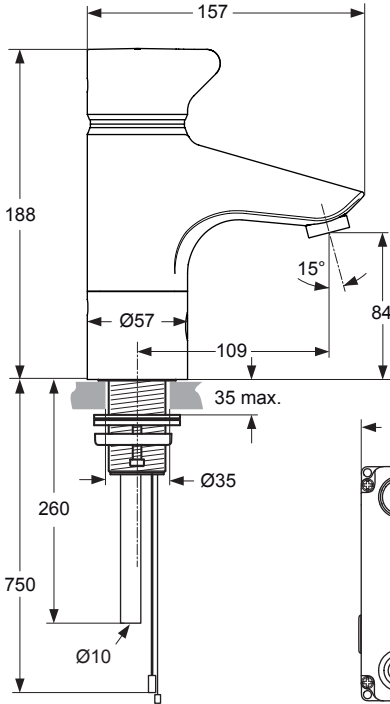

**Important:**

1. **Electrical connection:** mains electric powered version of this product must be connected to a continuous permanent power supply.
  2. **Sensor protector:** this black-out lens cover should only be removed from the sensor after completing installation & at least 20 seconds after powering up.
- See page 3 for more details.

**IMPORTANT**

**BEFORE CONNECTION, FLUSH WATER THROUGH PIPEWORK TO REMOVE ALL DEBRIS ETC. WHICH COULD DAMAGE THE VALVE MECHANISM**



**INSTALLER:** After installation please pass this instruction booklet to user

# TABLE OF CONTENT

---

1	IMPORTANT PRE-INSTALLATION NOTES .....	3
2	PRODUCT BOX CONTENTS .....	4
3	SUPPLY CONDITIONS.....	5
4	WATER REGULATIONS .....	5
5	INSTALLATION GUIDE.....	6
	5.1 MOUNTING .....	6
	5.2 PLUMBING OVERVIEW.....	7
	5.3 ELECTRICAL CONNECTION.....	9
6	TAP OPERATION.....	14
7	SENSOR RANGING .....	15
8	OUTLET OPTIONS.....	16
9	MAINTENANCE .....	16
	9.1 SOLENOID VALVE .....	16
	9.2 HYGIENE FLUSH (AUTOMATIC).....	17
	9.3 ISOLATING VALVE.....	18
10	SPARE PARTS.....	19
11	CLEANING CHROME SURFACES .....	20



## Sensorflow 21 standard & compact basin spouts with integral sensor

These basin mount Sensorflow 21 electronic products are designed for water economy & hygienic “no-touch” operation. If necessary the small lever handle can be used to adjust the water temperature.

The mixer is operated by the integral infrared sensor which is triggered by hand movement in the sensing region. When the hands are moved away, the water will stop automatically within a couple of seconds.

These products are designed to be supplied with premixed hot & cold water.

The two designs are available in 3 versions: Mains powered (transformed) with option to link up to 5 link units & independent battery powered units:

**A4176AA** supplied with **mains power unit**

**A4177AA** supplied with **link unit** (up to 5 per A4176AA )

**A4124AA** supplied with **battery unit**

# 1 IMPORTANT PRE-INSTALLATION NOTES



## MAINS ELECTRICAL POWER SUPPLY

Mains powered Sensor Operated Products must be connected to a (fused / switched) **continuous permanent power supply**.

Connection to an **interrupted power supply** intended to stop electrical consumption in an unused facility, may adversely affect this sensor product and is therefore not recommended.

Each time the power supply is reinstated the product briefly enters reprogramming mode.

During reprogramming mode, any interaction (passive or active) with the product may alter the sensor settings in respect to range and / or run duration.

No significant savings will be achieved by connection to an interrupted supply. These products are intrinsically economical in terms of both water and electrical energy and will shut down in the event of a sensor being obstructed.

## SENSOR PROTECTIVE COVER

This product is supplied with the sensor lens covered over with a black-out material.

**DO NOT REMOVE** this lens cover until the product installation has been completed & then wait for at least 20 seconds after powering-up.

The lens cover prevents the sensor from being unintentionally reprogrammed during the powering up sequence.

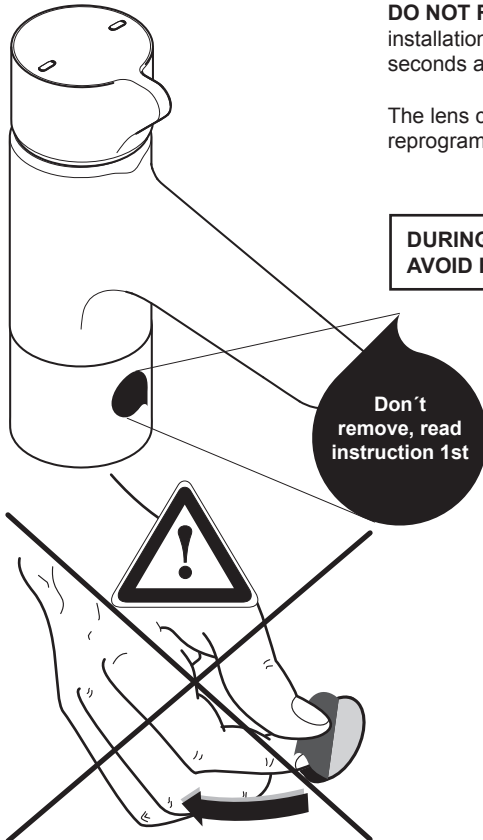

**DURING SETTING UP PROCEDURE  
AVOID HIGH VISIBILITY CLOTHING**



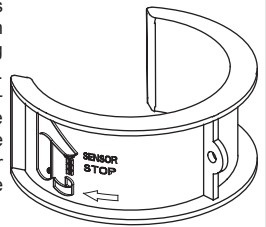

NOTE: An alternative sensor cover is supplied, but is intended to be used by cleaning staff. This cover prevents water flow from being triggered during cleaning. This flexible plastic cover can be snapped onto the spout body over the sensor. See section 6.

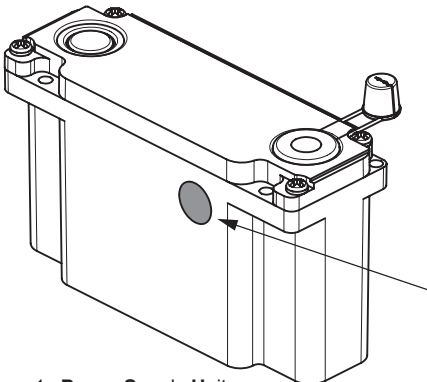
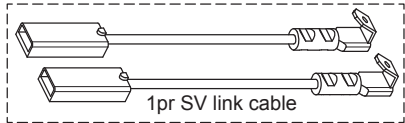
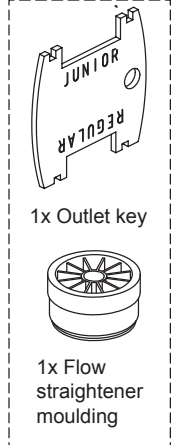
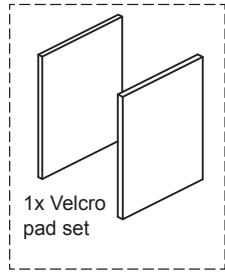
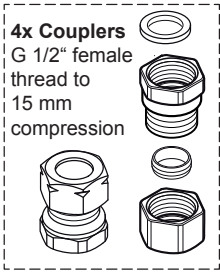
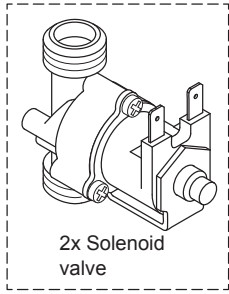
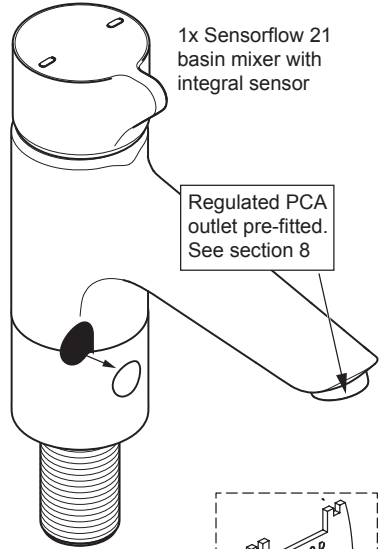
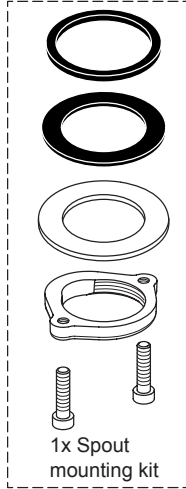
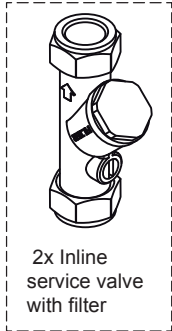
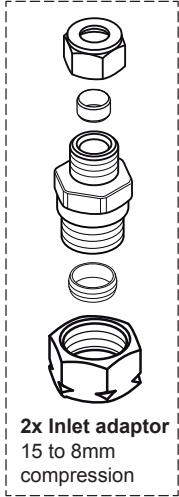

## 2 PRODUCT BOX CONTENTS



**Each type of PSU is identified by this coloured dot system:**

-  **REDACTED** MAINS
-  **BLUE DOT** LINK (Supplied with link cable)
-  **GREEN DOT** BATTERY (Supplied with battery)

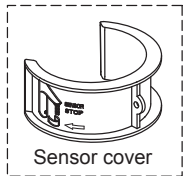
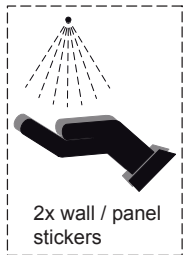



### Abbreviations & terminology used

**PSU:** Power Supply Unit, either mains, battery or link versions.

**PCB:** Printed Circuit Board inside the PSU.

**RCD:** Residual Current Device

**SELV:** Safety Extra Low Voltage

**LINK PSUs:** (up to 5 max) can be connected in series to a single mains PSU. Permitting washroom with multiple products to be run from a single mains supply point.

## 3 SUPPLY CONDITIONS

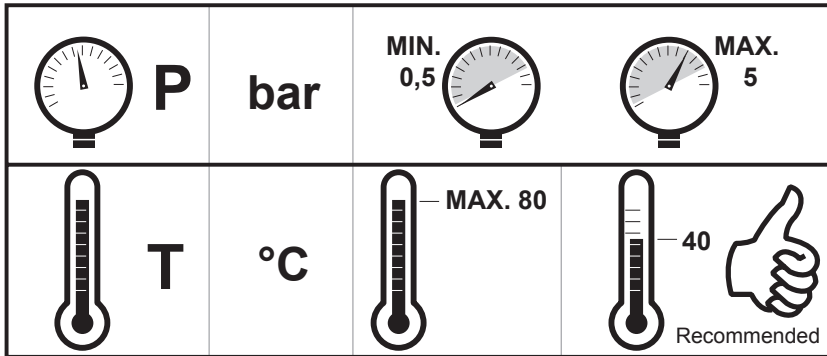

This product is designed to be supplied with water at a pre-mixed temperature on the hot inlet & cold water supply

In order to maintain water quality, the hot supply should be stored & distributed at a temperature greater than 55°C.

Use of an appropriate temperature reduction device (e.g. tee pattern thermostat) is recommended to ensure delivery of safe hot water temperatures from the mixer.

Avoid supplying scalding water to the spout. Hot water temperature supply should be controlled to circa 40°C.

## 4 WATER REGULATIONS

**The fittings covered by this installation and maintenance instruction should be installed in accordance with the water regulations published in 1999\*, therefore Armitage Shanks would strongly recommend that these fittings are installed by a professional installer**

\*A guide to the Water Supply (Water Fittings) Regulations 1999 and the Water Byelaws 2000, Scotland is published by WRAS (Water Regulations Advisory Scheme) Fern Close, Pen-y-Fan Industrial Estate, Oakdale, Newport, NP11 3EH.  
ISBN 0-9539708-0-9

# 5 INSTALLATION GUIDE



Before connection, flush water through pipe-work to remove all debris etc. to prevent damage to the valve mechanism.

THEN ENSURE WATER SUPPLIES HAVE BEEN ISOLATED.

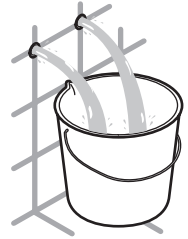

## 5.1 Mounting

1. Remove the mixer mounting kit if already assembled to the mixer tail. Ensure the basin rubber washer (smaller diameter one) is in place as shown. This seal should locate into the base recess of the mixer. Offer the mixer towards the basin hole.

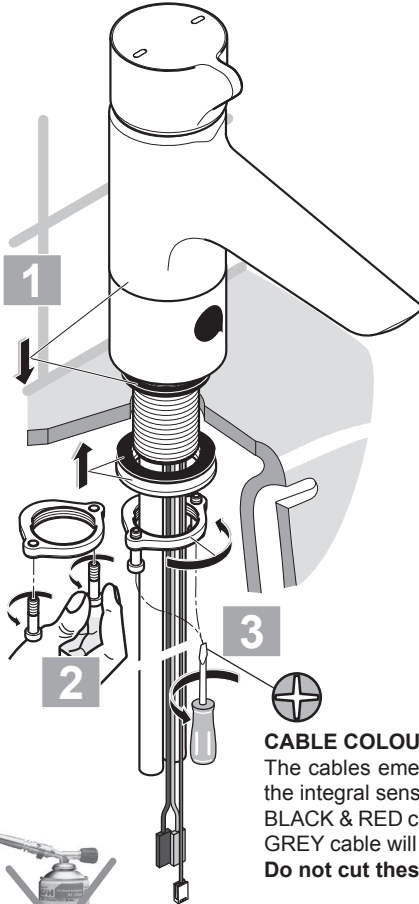

Feed the inlet pipe & cables through basin hole. The cables are protected by the black corrugated plastic tubing (split). Locate the mixer tail into the basin hole. Allow the mixer to rest on the basin seated on the rubber washer. Refit the corrugated tube if it slips off the cables.

2. Partially fit the two screws into the brass clamping ring as shown. From below the basin, fit the larger rubber washer, brass washer & clamping ring onto the spout tail as shown.

3. Hand tighten the clamping ring onto the tail so that the screws contact the brass washer which in turn pushes the rubber washer until it makes contact with the underside of the basin. Ensure the mixer is positioned correctly, & then tighten the screws securely with a posi drive screw driver

### CABLE COLOURS:

The cables emerging from the spout are connected to the integral sensor.

BLACK & RED cables will connect to the solenoid valve.

GREY cable will connect onto the PCB inside the PSU

**Do not cut these cables.**

**DO NOT** apply heat near this product. Heat generated by soldering could damage plastic parts and seals.

# INSTALLATION GUIDE continued...

## 5.2 Plumbing Overview

Once the spout has been secured to the basin, consideration should be given to installing & positioning of the inline valves.

A typical plumbing installation example is shown here. The water is being supplied from below, but can be from any direction.

Short lengths of Ø15mm copper pipe (not supplied) have been used between the components. Copper pipe lengths should be cut to suit the installation. Note the Ø10mm inlet pipe (fitted to spout) can be trimmed if necessary.

Observe arrow markings on the valves as shown here. Ensure water flows in the direction indicated.

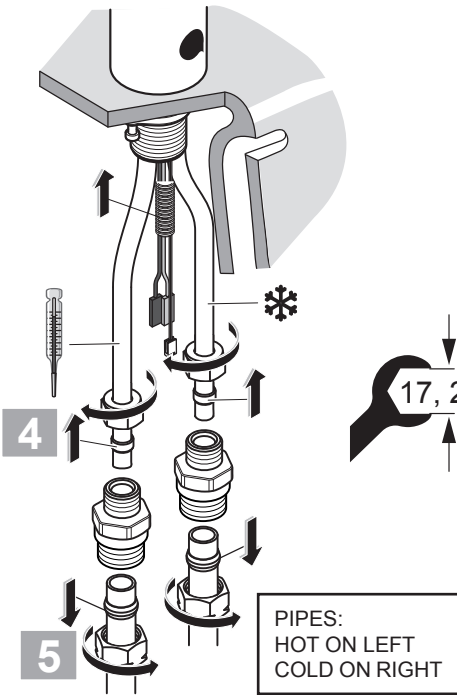

**4. To fit inlet adaptor:** Slip the small compression nut & olive onto the Ø10mm inlet pipe. Push the adaptor onto the inlet pipe up to the shoulder. Slide the olive up to the adaptor & tighten the compression nut (17mm A/F) with an adjustable spanner. Hold the adaptor steady with 22mm A/F spanner.

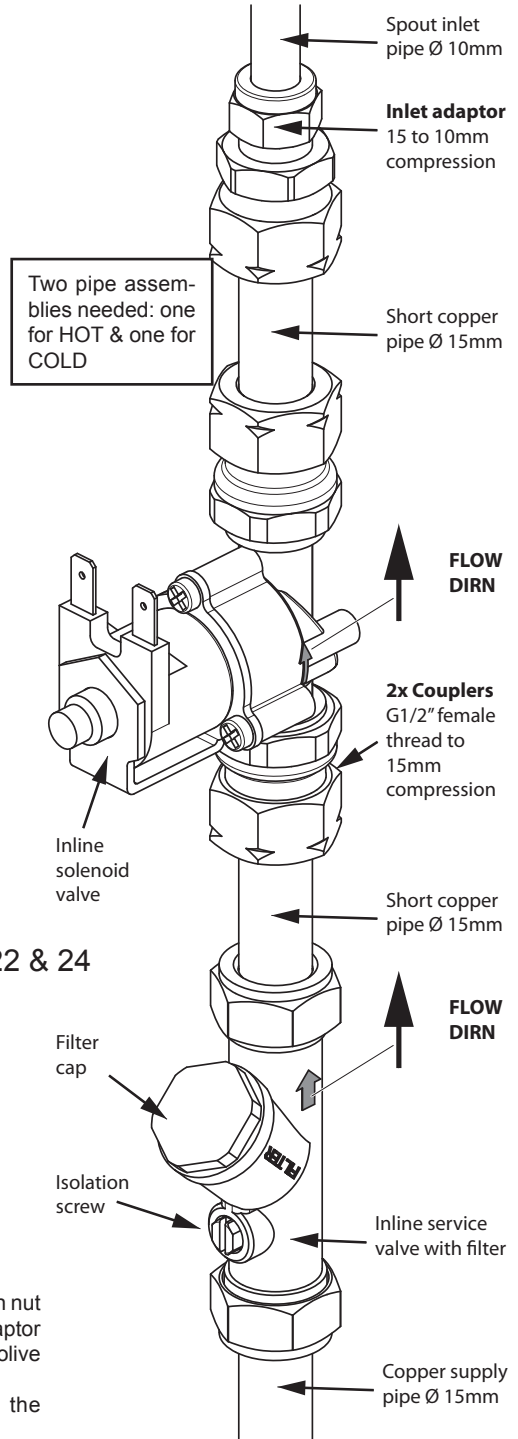

## INSTALLATION GUIDE continued...

**5. To fit inlet adaptor cont:** Slip the larger compression nut & olive onto a short length of Ø15mm supply pipe. Push the supply pipe into the adaptor up to the shoulder. Slide the olive up to the adaptor & tighten the compression nut with a 24mm A/F spanner. Hold the adaptor steady with a 22mm A/F spanner.

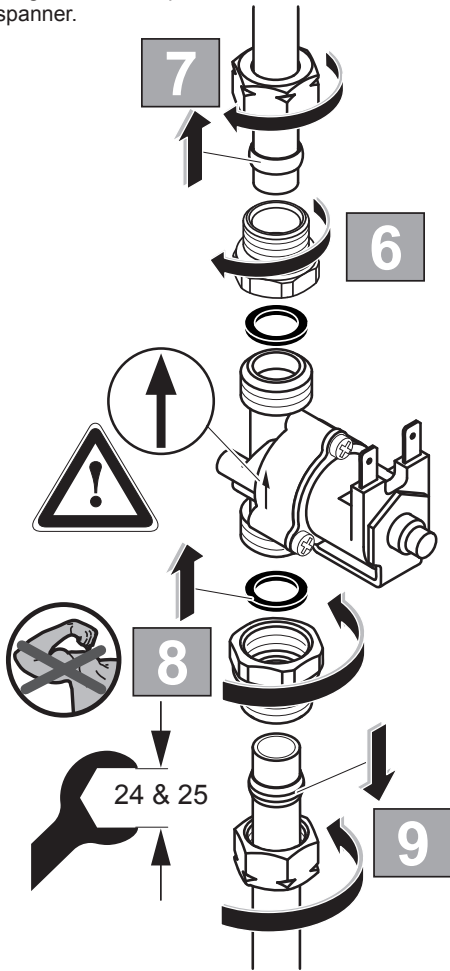

### 6 & 8. To fit solenoid valve:

The couplers can be screwed onto both sides of the in-line solenoid valve. Ensure the seals provided are fitted as shown. Make good the joints, taking care not to use excessive force. Tighten with an adjustable spanner (25mm A/F).

**7 & 9.** Slip the compression nuts & olives onto the pipes. Fit the solenoid valve into the pipe-work & make good the joints. Observe flow direction.

Make sure the solenoid valve is orientated such that the electrical connectors are easily accessible.

### 10 & 11. To fit service valve:

Slip the compression nuts & olives onto the pipes. Fit the service valve into the pipe-work & make good the joints. Observe flow direction. Make sure the service valve is orientated such that the filter cap & isolating screw are easily accessible for future maintenance.

When the isolator screw slot is parallel to the valve body, the valve is open & permits water to flow. To close the valve, rotate the isolator screw 90°.

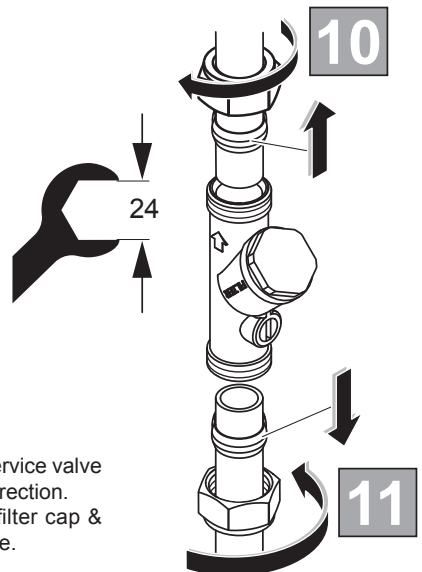

**Check that all joints are securely tightened, test for leaks.**



## INSTALLATION GUIDE continued...

### 5.3 Electrical connection

Connection of this product to mains power supply should be undertaken by a competent person and should conform to IEE Wiring Regulations

Orientation & position of solenoids, and PSU (Power Supply Unit) case can differ from installation to installation.

With the product securely mounted to the basin & plumbed-in, electrical work can commence.

**12.** First connect the two solenoid valves together using the separate SV link cable provided. The SV link cable is black & red with connectors at both ends.

SV link cable length is 500mm.

Note: one end of the SV link cable has additional spade connectors for attaching the sensor cable.

Connect the cable to the solenoid valve terminals as shown. Observe the + and - symbols marked on the solenoid valves, connect the red cable to + & black to -.

Locate the end of the red & black cable which emerges from the spout tail (attached to the rear of the sensor). This cable length is nominal 800mm.

Connect this cable to the spade connectors shown on the SV link cable. Observe the + and -. Ensure red is connected to red & black to black.

Refer to the diagram on the next page for PSU connection options.

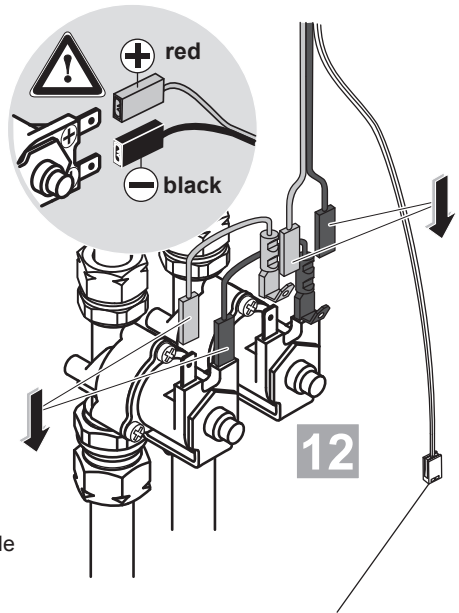

Each type of PSU is identified by this coloured dot system:

RED DOT MAINS

BLUE DOT LINK

GREEN DOT BATTERY

### Electrical information & approvals:



Power: **6W**

Input voltage:  
**100V - 240V~ 50 - 60Hz**

Protection class: **II**

Approval EU:  
**EN 60950, EN 60335**

Approval UL: **UL 1310**

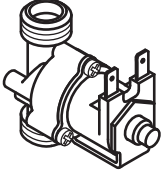

DIN EN 60730-1: Type 1



# INSTALLATION GUIDE continued...

## Electrical connection continued...

ENSURE MAINS POWER SUPPLY IS SWITCHED OFF BEFORE COMMENCING

13. Open the PSU case by unscrewing 4x posi-drive screws.

14. The lid & seal should separate from the PSU case.

15. For battery version, orientate the battery correctly & slide it into the PSU as shown, until it clicks into position  
For mains version, slide out **Printed Circuit Board (PCB)**.

16. For mains version, press out the “knock-out” at the base of the PSU case for mains cable entry.

17. For link version, slice the grommets fitted in the side wall of the PSUs to allow entry for the link cable(s).

18. For mains version, fit a grommet into the hole in the base of the PSU. Feed the power supply flexible cable through this grommet & make connections to terminal block on the PCB. Refer to 28.

19. For link version, feed the link cable through the side wall grommet in the PSU & plug it onto one of the sockets on the PCB. Refer to 28.

ALTERNATIVELY, the link cable can be routed through the PSU lid as shown in 24, along with the sensor cable.



20. Slide the PCB back into the PSU ensuring cables are not trapped.

21. For link version, plug the other end of the link cable into the socket on the link PCB.

22. For link versions, plug additional link cables into the sockets on the link PCB.

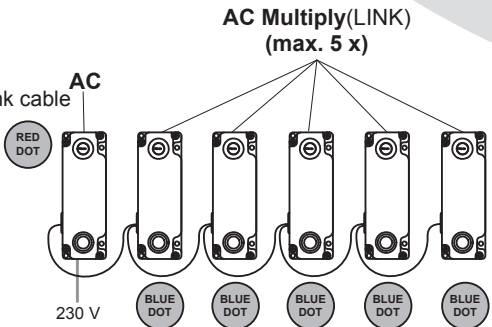
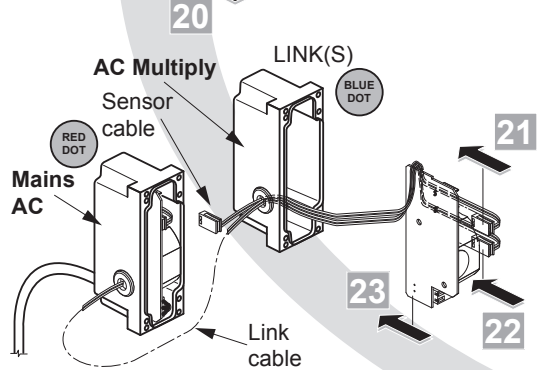
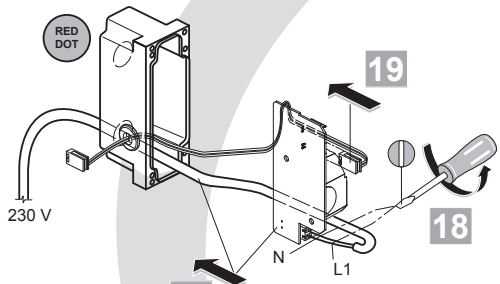
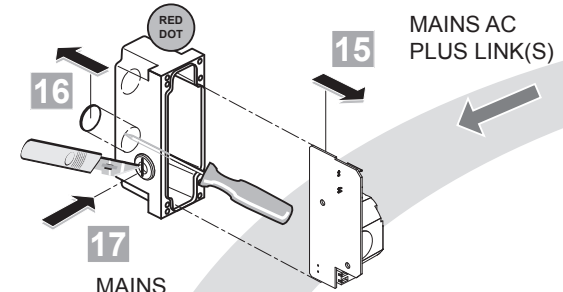
23. Slide the link PCB back into the PSU ensuring cables are not trapped.



Each type of PSU is identified by this coloured dot system:	
	MAINS
	LINK
	BATTERY

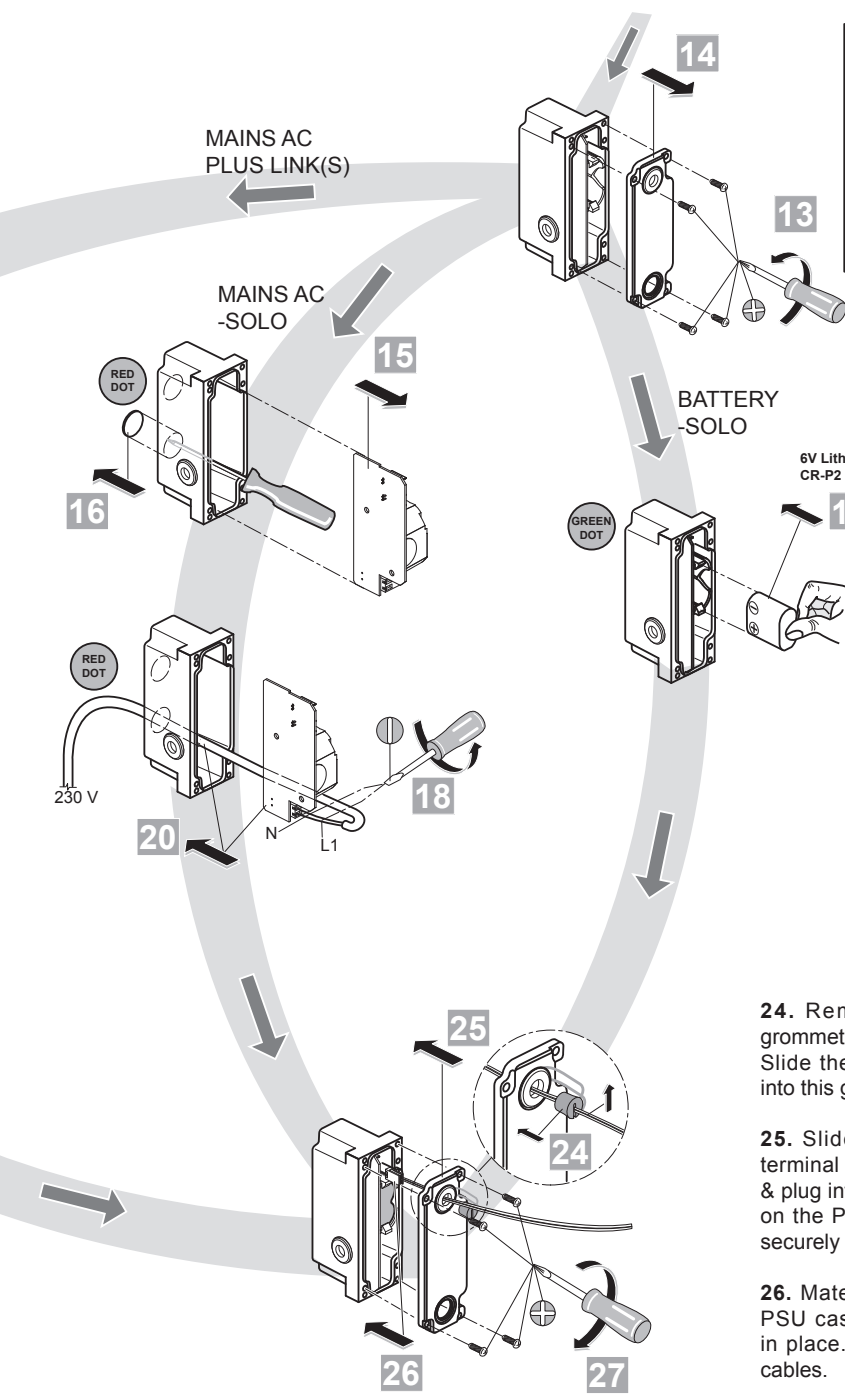

**24.** Remove the pre-split grommet from the PSU lid. Slide the grey sensor cable into this grommet.

**25.** Slide the sensor cable terminal through the PSU lid & plug into one of the sockets on the PCB. Press grommet securely into the lid.

**26.** Mate the PSU lid to the PSU case, ensuring seal is in place. Avoid trapping any cables.

**27.** Refit the 4 lid screws securely.

# INSTALLATION GUIDE continued...

## Electrical connection continued...

**28. Mains power cable** (not supplied) should be flexible 3A rated (multi-strand) 2 core cable. Prepare the cable for connection into the PCB by carefully stripping back the outer sheath by about 100mm. Strip the wire ends back by about 5mm.

**PCB connection:** the appropriate wires of the mains cable should be connected to the appropriate terminal on the block. The PCB is marked L1 for the live wire & N for the neutral wire. Earth connection is not required.

**IMPORTANT:** Ensure terminal block screws are firmly tightened & clamp the wires securely.

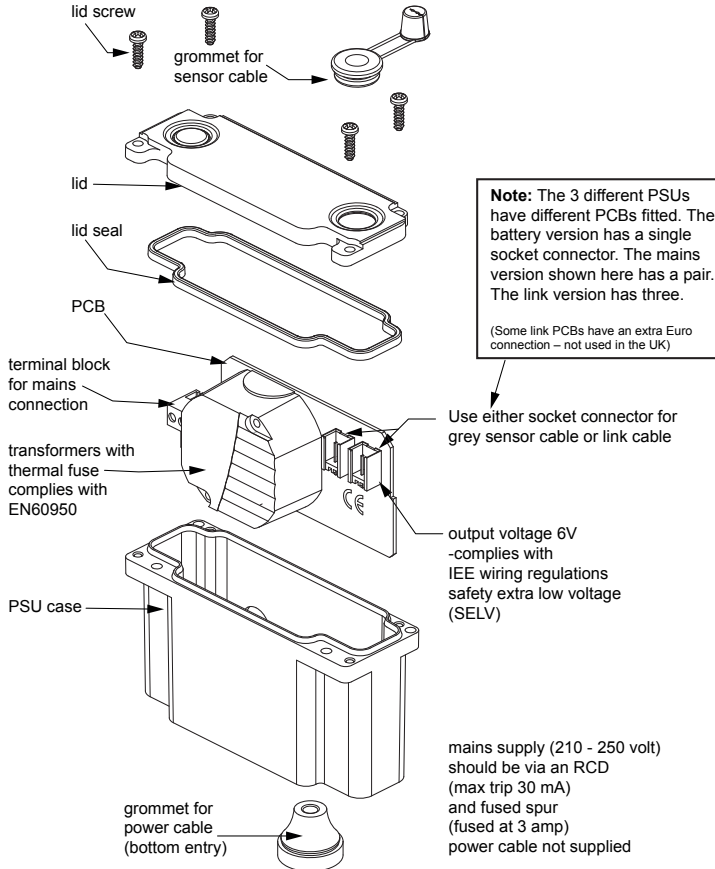

**Shown above: Mains Power Supply Unit (PSU)**



### Other cable information:

Two cables emerge from the spout tail these are connected to the integral sensor. Both cables have nominal lengths of 800 mm.

BLACK & RED cable will plug onto the terminals on the solenoid valve.

GREY cable (with black line) will plug into one of the sockets on the PCB inside the PSU.

Link cable is also GREY (with black line), length is 1.5M (supplied with link product only)  
SEE SECTION 7 FOR CABLE EXTENSION DETAILS & FURTHER CABLE NOTES

# INSTALLATION GUIDE continued...

## Electrical connection continued...

A pair of self-adhesive Velcro-type pads are provided. Attach one to the side of the PSU case & the other to a suitable location on the rear of the mounting panel.

Ensure the selected location does not stretch/stress the cables. Consideration should also be given to keeping the PSU case within easy reach/access for maintenance staff.

### IMPORTANT:

Leave the sensor protective sticker in place for at least 20 seconds after powering-on the product. See section 7 regarding sensor ranging.

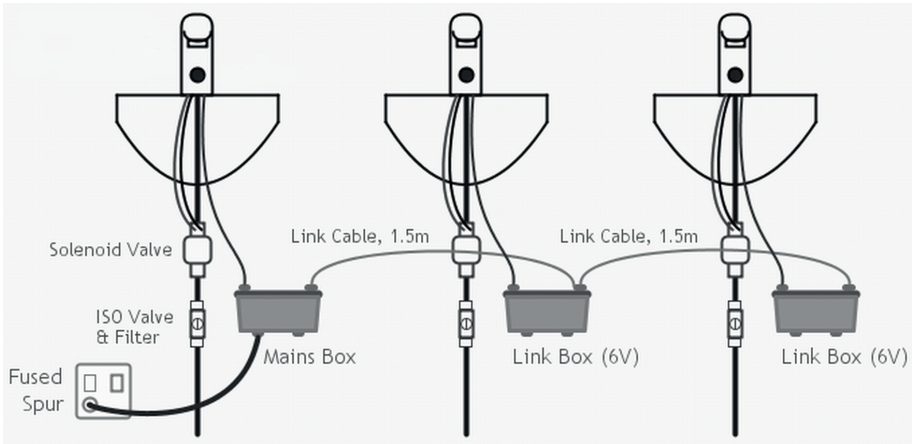

Example of an installation where 1st PSU is mains plus 2x link PSUs.

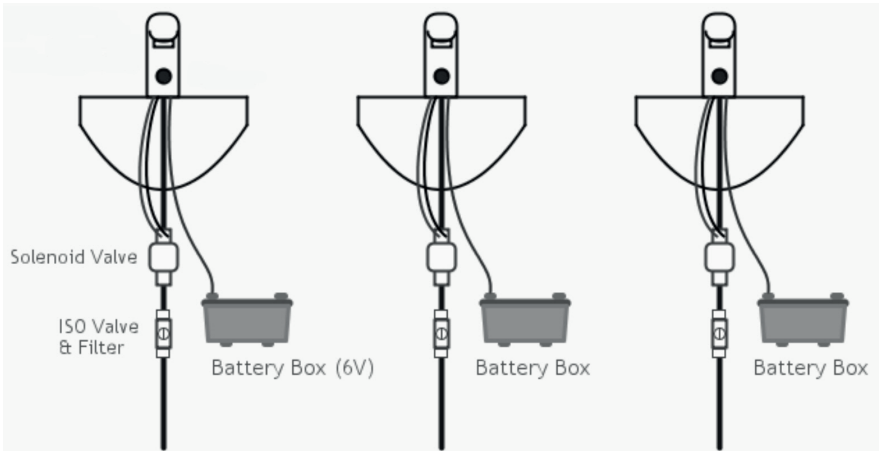

Example above of an installation where PSUs are all battery versions..

## INSTALLATION GUIDE continued...

### Electrical connection continued...

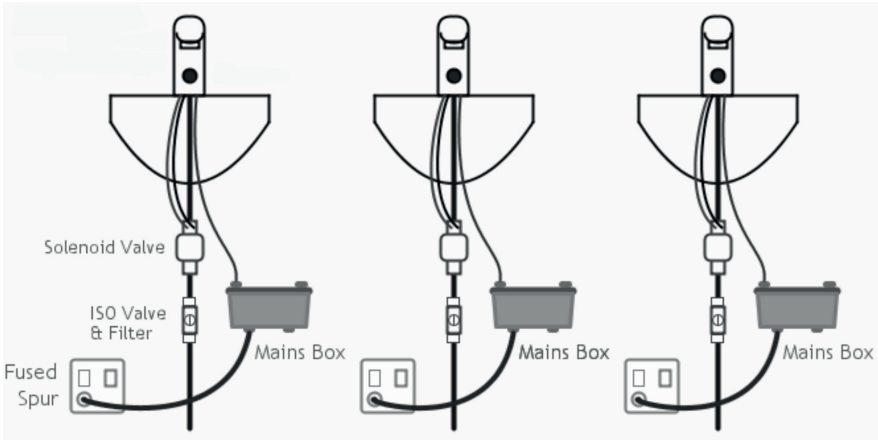

Example above of an installation where PSUs are all mains versions.

**Sensor taps stickers:** To complete the installation, 2 stickers are provided which can be stuck onto a wall or panel in close proximity to this product to advise the end user that this product sensor operated.

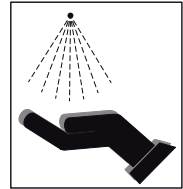

## 6 TAP OPERATION



Sensorflow 21 products use an Infrared Sensor to activate the system. The sensor is triggered by something reflective (normally hand movement) in the Sensing Region. Sensor is located at the base of the spout & is forward facing.

Move hands towards the mixer:  
Water will flow.

Move hands away from the spout:  
Water will continue to flow for a second or two, and then turn off.

Sensor is factory set to **Proximity Mode**, & is designed to trigger the water flow **only when a hand (or similar) is in the Sensing Region** – just in front of the sensor / outlet.

Lever handle can be rotated as shown to adjust water temperature. Clockwise rotation provides warmer water

NOTE: If the plastic cover (supplied) is fitted over the sensor, water flow will stop & thus allow the product to be cleaned without triggering the sensor.

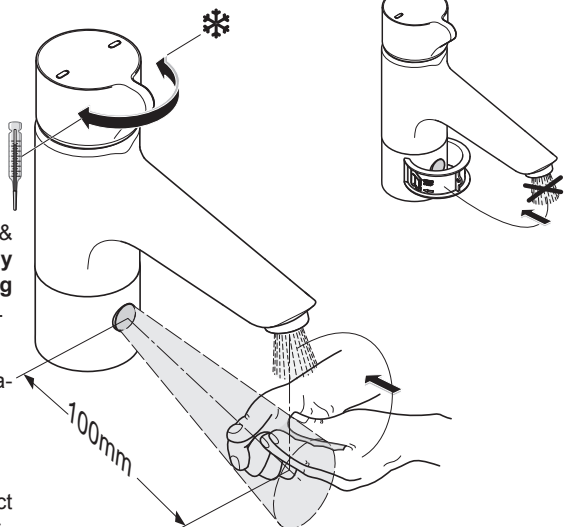

# 7 SENSOR RANGING

If the Sensor detects a strong reflection (or similar), the spout will turn on and off intermittently with no one present (Pulsing On / Off). In the unlikely event that this does happen, the Sensing Range must be reduced. This can be done using one of two ways: (A) manually or by (B) using a remote sensor programming unit.

**Default factory range setting is 100mm**



### A. Manually Changing Sensor Range

1. Turn Power to sensor OFF.
2. Wait 60 seconds, turn power ON . . .
3. Red light in sensor flashes for 5 seconds
4. **While light is flashing**, move hand very close to sensor (A) (palm towards sensor)
5. When light goes SOLID RED move hand to end of spout (B)  
(This will set the Sensing Range)
6. When light starts to flash again, Move hand away from Sensor / Tap.
7. Wait 5 seconds for sensor to store data.
8. Sensor Range is now set.
9. Check tap works properly by bringing hand towards spout.

(Total range is from 50mm to 250mm).

**DURING SETTING UP  
PROCEDURE AVOID HIGH  
VISIBILITY CLOTHING**



**B. Remote sensor programming unit** is a hand held unit which can be used to change sensor range & other functions if required. Detailed instructions for using this unit are provided with the unit. (This unit can be purchased separately. For spares code, see section 10).

See maintenance section for a quick overview of how to use this unit to evoke the optional hygiene flush function.



### **Extension cables**

If the installer wishes to position the PSU in the ceiling area for example, then cable extensions are available:

SENSOR & SOLENOID EXTENSION LEADS: A963703NU: (Pair, 2M long).  
Containing grey power lead for sensor & black/red lead for solenoid.

LINK CABLES: A962281NU (1.5M), A962282NU (3M) & A960707NU (10M).



**CABLES SHOULD NOT BE CUT (OR SHORTENED), AS THIS WILL INVALIDATE WARRANTY.**







For more information on spare parts why not visit our spare website:  
**[www.fastpart-spares.co.uk](http://www.fastpart-spares.co.uk)**. Or contact customer care

## 8 OUTLET OPTIONS



This product comes with two outlets one fitted & the second supplied in a bag. The product is factory fitted with a laminar PCA regulated outlet which is secured within an anti-vandal (AV) housing.

Unregulated full-flow flow straightener (SUPPLIED LOOSE)	<b>P</b>  <b>Q</b>  0.5 bar 4.2 l/min
Regulated PCA outlet (> 1.0 bar) (FACTORY FITTED)	<b>P</b>  <b>Q</b>  3.0 bar 4.7 l/min

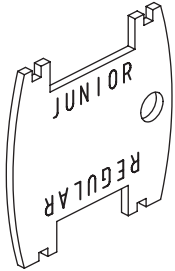

To replace/clean/service the outlet, use the outlet key supplied with the product to unscrew the AV housing. Using the side of the key marked "junior" locate the key into the inner ring of the housing and unscrew. Change the outlet & re-secure the housing with the key, ensuring the seal is in place.

Ensure the outlet housing is adequately tightened to prevent leaks & run back.

## 9 MAINTENANCE

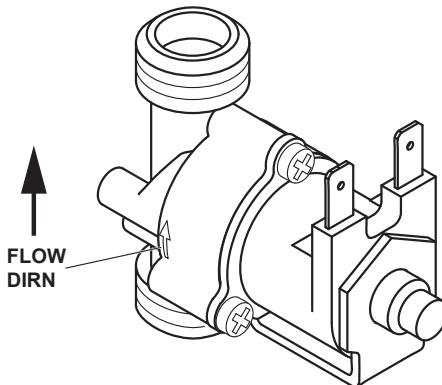

### 9.1 SOLENOID VALVE

If **water continues to flow** when the tap should be off, and if the sensor is correctly ranged, then the solenoid valve may have debris lodged in the diaphragm pilot hole or on the valve seat:

- Locate the solenoid valve.
- Isolate the water supplies.
- Disconnect the solenoid valve cables.



## Maintenance continued...

- Remove the 3 screws holding the coil.
- Lift off the coil assembly.
- Locate the diaphragm (inside the valve body).
- Clean out the pilot hole(s) – use a thin gauge fuse wire (or similar).

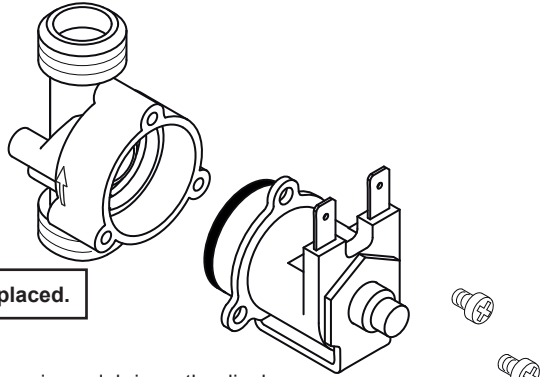

**If diaphragm is damaged it should be replaced.**

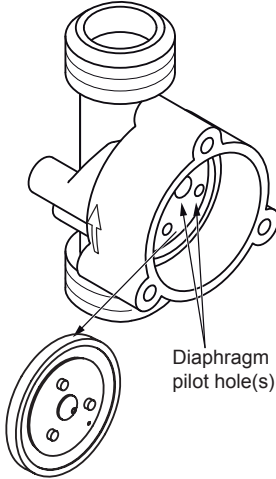

- Ensure there is no debris on the diaphragm or the valve seat (under diaphragm).
- Re-assemble solenoid valve.
- Reconnect water supply, check there are no leaks.
- Reconnect the solenoid valve cables.
- Test the solenoid valve & ensure it is working correctly.

If the solenoid plunger becomes dislodged from its bore, **ensure it is refitted correctly. The end with the small black insert should face towards the diaphragm.**

Incorrect assembly will cause continual running.

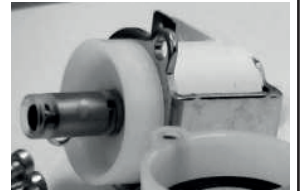

## 9.2 Hygiene flush (Automatic)

This hygiene flush is an important optional function of these products which can be enabled by the installer or maintenance staff using the optional remote programming unit (for part number see sect.10).

The hygiene flush is used to combat periods of stagnation due to low usage of the product. The function activates the spout automatically if it hasn't been used for a set time period. This function ensures regular movement of water combating bio film growth and bacteria colonisation.

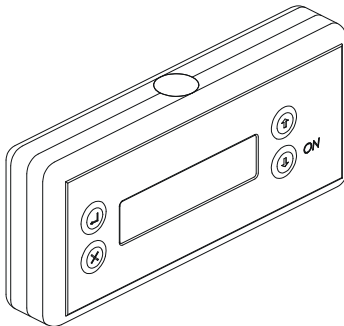

The programming unit should be held pointing towards the sensor at distance of approx. 100mm.

Once enabled, this function will automatically turn the water on for a duration of 1 to 240 seconds if the product has not been used for a period of 6, 12, 24, 48, or 72 hours.

For full details on how to enable this function, refer to the programming instructions supplied with programming unit.

**Keep hand unit away from the water flow, avoid getting it wet.**

## Maintenance continued...

A brief summary of how to navigate the programming unit is as follows:

- a) Hand unit ON
- b) Navigate to Menu **4 PARAMETER**
- c) **SENSOR 2013** (Enter)
- d) **MENU 4.1 HAND-WASH** (Enter)
- e) **AUTO-RINSE FREQUENCY: OFF**  
ARROW UP (To required Delay time) (Enter). Recommended: 6 or 12 hours.
- f) **AUTO-RINSE DURATION: (15 seconds default)**  
ARROW UP or DOWN (To required Run Time). Recommended: 60 seconds (max).
- g) Point towards Sensor (approximate distance 100mm)
- h) Press ENTER
- i) **TRANSMISSION OK** - if successfully programmed;  
**ERROR COMMUNICATION 2** - if programming failed
- j) Press ESCAPE (X) to get **BACKUP FUNCTION**
- k) With BACKUP FUNCTION, previous settings are 'Remembered'  
- just point at next Tap / Sensor and press ENTER to repeat.
- l) Hand unit turns itself off after 2 minutes of non-use.

Note: Older handset units will display (c) **SENSOR 2008** (or 2003) by default.  
Failed program output message will be (i) **ERROR COMMUNICATION 3**.  
Latest handset can program all previous sensor versions 2013, 2008 & 2003.

### 9.3 Isolating valve

Isolation valve (supplied with this product) **MUST** be fitted to permit future maintenance of the product. A strainer (filter) is built into this valve.

Isolation valve should be installed in an easily accessible location.

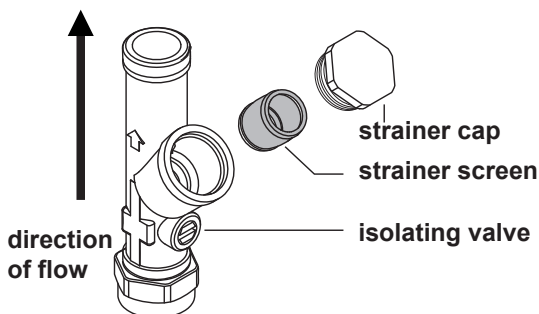

When the isolator screw slot is parallel to the valve body, the valve is open & permits water to flow. To close the valve, rotate the isolator screw 90°.

The filter can be checked & cleaned by unscrewing the cap using a 22mm A/F spanner. Expect some water to escape. The isolating valve can be closed to permit servicing of the solenoid valve, or to remove the product completely.

# 10 SPARE PARTS

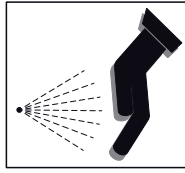

A 960 402 NU  
Legend plates

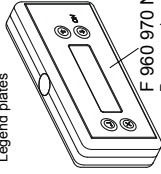

F 960 970 NU  
Programming unit

A 962 857 NU  
Grub screw

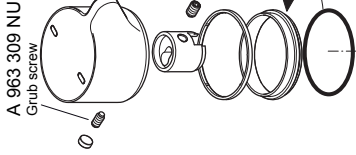

A 963 309 NU  
Grub screw

A 961 338 NU  
O-rings

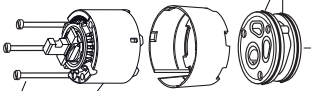

A 963 333 NU  
Cylindrical screw

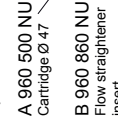

A 960 500 NU  
Cartridge Ø 47

B 960 860 NU  
Flow straightener  
insert



B 960 859 AA  
Aerator complete  
with AV key

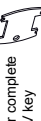

A 960 486 NU  
Fixing kit

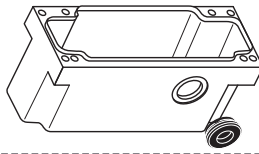

A 961 335 NU  
O-ring

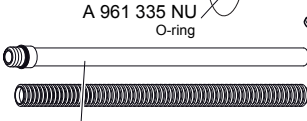

A 963 289 NU  
Adaptor 10 - 15mm



B 960 459 NU  
Inlet tube

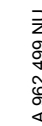

A 962 499 NU  
Couper (solenoid)



A 960 224 NU  
Diaphragm (10 pk)



A 960 201 AA  
Screws



A 962 478 NU  
Solenoid complete

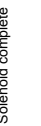

A 962 499 NU  
Couper (solenoid)

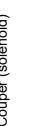

E 960 086 NU  
Servive valve



A 961 182 NU  
O-ring only (x2)

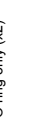

A 960 219 NU  
Sensor complete

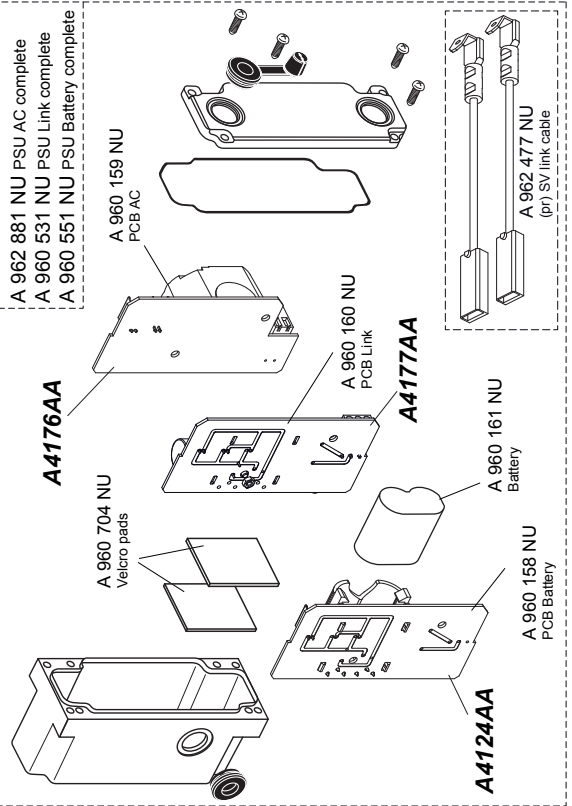
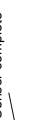

A 962 881 NU PSU AC complete  
A 960 531 NU PSU Link complete  
A 960 551 NU PSU Battery complete

A 960 159 NU  
PCB AC

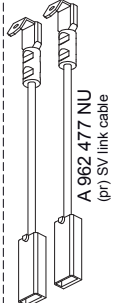
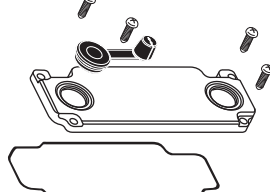

A 962 477 NU  
(pr) SV link cable

A 4176AA

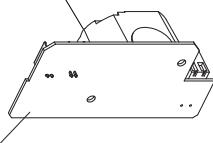

A 960 704 NU  
Velcro pads

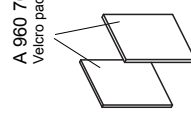

A 960 160 NU  
PCB Link



A 4177AA

A 960 161 NU  
Battery



A 960 158 NU  
PCB Battery

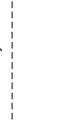

A 4124AA

FOR LONGER CABLE OPTIONS,  
REFER TO SECTION .7



For more information on spare parts why not visit our spare website:  
[www.fastpart-spare.co.uk](http://www.fastpart-spare.co.uk). Or contact customer care

# 11 CLEANING CHROME SURFACES

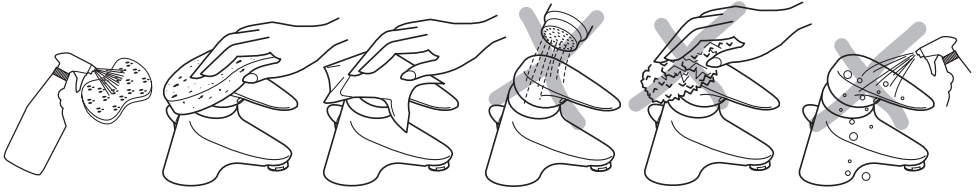

When cleaning chromed products use only a mild detergent, rinse & wipe dry with a soft cloth. Ideally clean after each use to maintain appearance.

Never use abrasive, scouring powders or scrapers. Never use cleaning agents containing alcohol, ammonia, hydrochloric acid, sulphuric acid, nitric acid, phosphoric acid or organic solvents. Use of incorrect cleaning products / methods may result in chrome damage which is not covered by the manufacturer's guarantee.

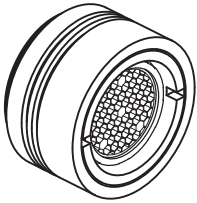

**Outlet cleaning.** On a regular basis the outlet should be inspected & cleaned. To unscrew and remove the outlet, see section 8. In areas where lime scale build-up is prevalent this should be avoided by regular cleaning. If it should build up, it will have to be removed. An inhibited proprietary scale solvent can be used such as a kettle de-scaling solvent but it is important to follow the manufacturer's guidelines. After de-scaling it is important to rinse the parts thoroughly in clean water. Clean carefully and do not use abrasive materials or scrapers.



For more information about our products visit our websites:

[www.armitage-shanks.co.uk](http://www.armitage-shanks.co.uk)

[www.idealspec.co.uk](http://www.idealspec.co.uk)

[www.fastpart-spares.co.uk](http://www.fastpart-spares.co.uk)

**AFTER SALES NON RESIDENTIAL HELPLINE**

**0870 122 8822**

**AFTER SALES NON RESIDENTIAL FAX**

**0870 122 8282**

**E-MAIL**

[aftersalesnonresidential@idealstandard.com](mailto:aftersalesnonresidential@idealstandard.com)

1117 / A 866 850

Made in Germany

Armitage Shanks pursues a policy of continuing improvement in design and performance of its products.

This right is therefore reserved to vary specification without notice.

Armitage Shanks is a division of Ideal Standard (UK) Ltd

Armitage Shanks

The Bathroom Works, National Avenue

Kingston-upon-Hull, HU5 4HS England

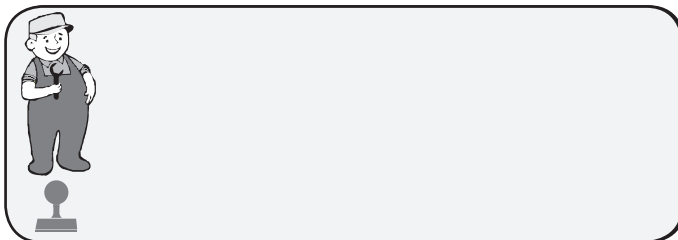

# Armitage Shanks

Ideal Standard International NV  
Corporate Village - Gent Building  
Da Vincilaan 2  
1935 Zaventem  
Belgium