

*Armitage
Shanks*

Armitage Shanks
Armitage,
Rugeley,
Staffordshire.
England.
WS15 4BT.
Telephone: 01543 490253
Fax: 01543 491677

CUSTOMER CARE HELPLINE
0870 1296085
CUSTOMER CARE FAX LINE 01482 499611
e mail : ukcustcare@aseur.com

Armitage Shanks pursues a policy of continuing improvement in design and performance of its products. The right is, therefore, reserved to vary specifications without notice.

A Division of
American Standard Plumbing (UK) Ltd.

4395 08/04

ARIDIAN UNIVERSAL WATERLESS URINALS 41mm OUTLET

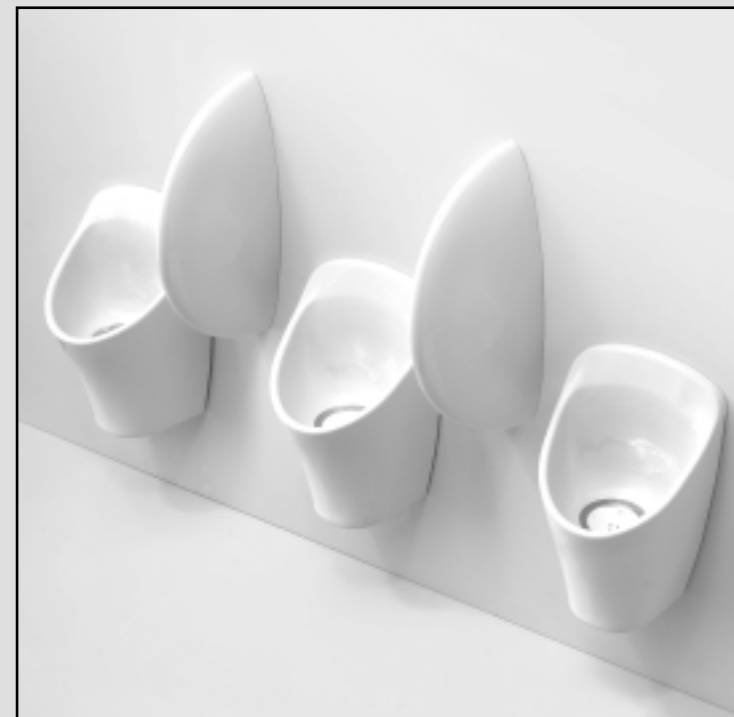

Installation Instructions

TECHNICAL INFORMATION

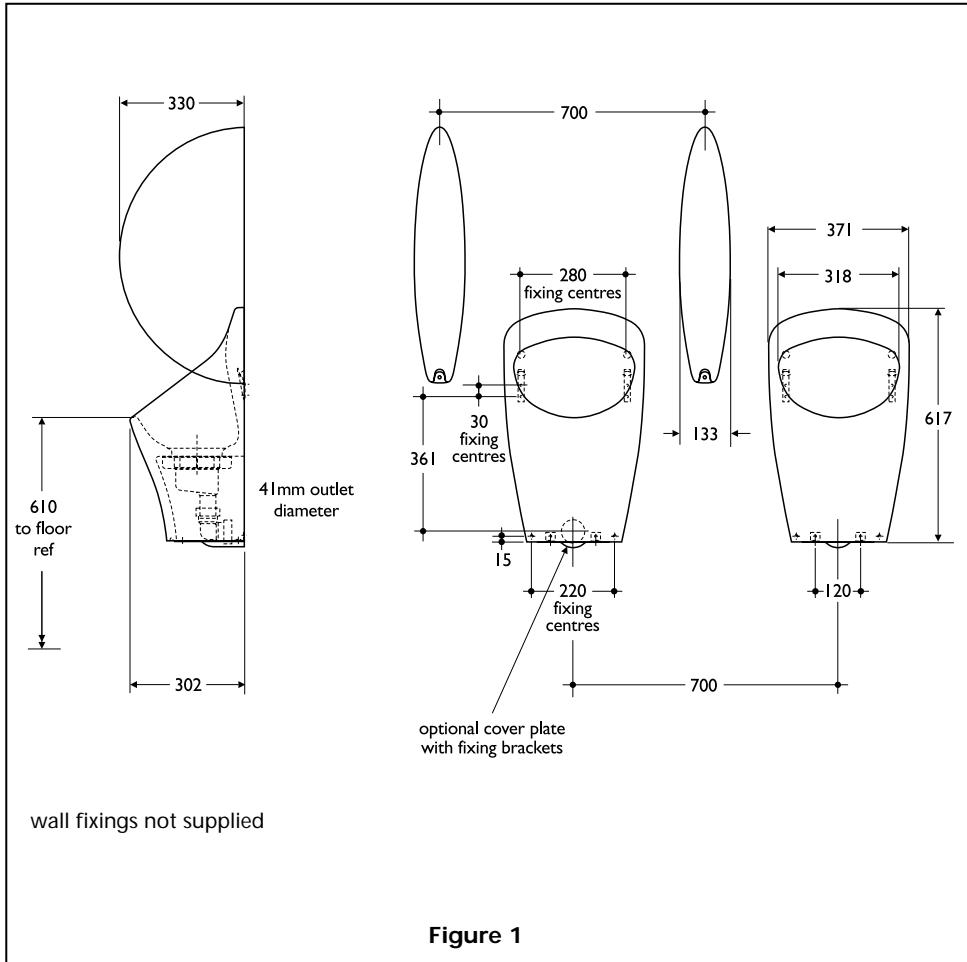

IMPORTANT

Please ensure that pipework is adequately vented, otherwise urinal may not function correctly.

The waterless unit is a waste trap.
DO NOT FIT ADDITIONAL TRAPS IN THE WASTE PIPEWORK
 as this will adversely affect the operation of the cartridge.

CARTRIDGE REPLACEMENT

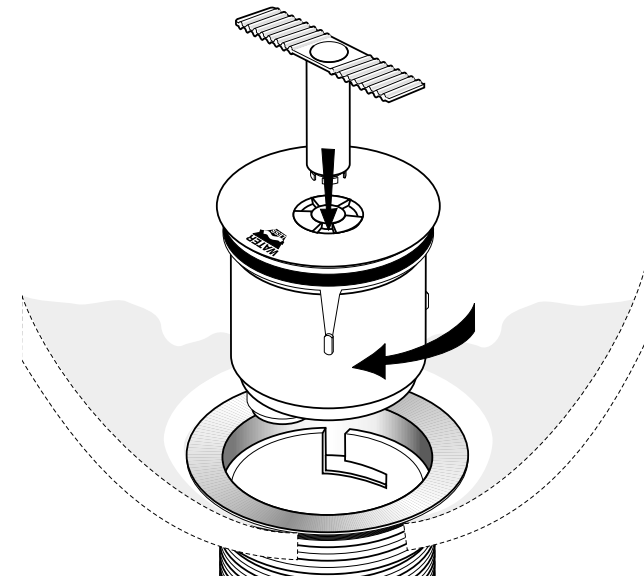

Figure 2

CARTRIDGE RENEWAL

Replacement cartridge packs are available through local stockists.

	Uses Per Day	Renew
Heavy Use	175 - 300	3 - 6 Weeks
Medium Use	75 - 175	6 - 12 Weeks
Light Use	75 or less	12 Weeks

For renewal of the cartridge, please refer to removal instructions in the cartridge pack.

The average lifespan of the waterless cartridge is approximately 7000 uses.

Do not allow buckets or similar containers to be emptied into the urinal as this will affect its operation and will lead to cartridge replacement

Do not use powder based cleansers, otherwise blockages may occur.

Please take careful note of all instructions in the cartridge pack and install / dispose of the cartridge correctly.